PRACTICE NOTE 21

FARM DAIRY EFFLUENT PONDS

Engineering Practice

ISSN 1176-0907
Version 3, August 2017



PREFACE

The purpose of this Practice Note is to provide good practice guidance on the design and construction of Farm Dairy Effluent (FDE) Ponds.

Inadequately designed effluent ponds can adversely affect the environment through leakage, overflow, or poor siting. Inadequate design can also adversely affect the health and safety of people and animals.

The information contained in this Practice Note is relevant for farm owners and operators, designers, constructors and consenting authorities. It is important that all people involved in the design or construction monitoring of effluent ponds follow this guidance whether they are Chartered Professional Engineers and members of the Institution of Professional Engineers New Zealand (IPENZ) or otherwise regarded as competent by regional consenting authorities. It should also be noted that regional councils may draw on the guidance in this Practice Note when producing their own policies related to effluent ponds.

This document is complementary to the following dairy industry IPENZ Practice Notes:

Practice Note 27: Dairy Farm Infrastructure (PN27)

Practice Note 29: Dairy Housing (PN29).

While this Practice Note specifically refers to FDE, there are other agricultural industries that produce effluent that may benefit from this guidance.

PRACTICE NOTE DEVELOPMENT

In early 2011 members of the Institution of Professional Engineers (IPENZ), together with support from principal sponsors DairyNZ, brought together other professionals from civil, geotechnical, agricultural, and environmental engineering backgrounds to develop a Practice Note on the design and construction of FDE ponds.

The development of *Practice Note 21* Version 1 was initiated by:

- Growing concerns expressed by both IPENZ members and farmers on the poor quality of FDE ponds being designed and constructed in New Zealand
- The impact that poor-quality FDE ponds were having on the environment
- Identification that regulatory requirements under the Building Code were not being similarly understood by some authorities
- Lack of clear definition as to who is competent to design and monitor construction for FDE ponds and structures
- Recognition by IPENZ and DairyNZ for the need to set industry standards for FDE pond design and construction.

The IPENZ Engineering Practice Advisory Committee (EPAC) gave the authors the task of preparing a document that reflects a national perspective to be adopted by the dairy engineering industry.

The Practice Note's objective was to provide good-practice guidelines for professional engineers and other technical specialists who are involved in the design and construction of FDE ponds. This Practice Note was also intended to be a good-practice reference source for Regional Council (RC) and Local Authority (LA) staff, agriculturists, product suppliers, contractors, and others involved in the FDE pond industry. In addition, the authors reviewed New Zealand legislation and regulations and sought to interpret these as they relate to FDE ponds and structures.

To maintain an up to date and industry relevant document, *Practice Note 21* underwent a review in late 2012. Following consultation, three new parts were added: clay liners, geomembrane (synthetic liner) selection, and ponds and tanks on peat and was released as version 2 (March 2013). A further review was undertaken in mid-2017 driven mainly by legislative changes. Following industry consultation Version 3 (this version) was released. It includes a case study in Part 4 on FDE ponds constructed in Hauraki 'Marine' Clay.

DairyNZ continues to raise the profile of effluent management in New Zealand. Their *FDE Design Code of Practice* and the *FDE Design Standards* provide generic guidance for the design and development of effluent management systems. This distinctly separate Practice Note complements these documents.

In designing FDE pond systems, several other documents may need to be referred to and the *References* section at the back of this Practice Note links to a few relevant publications.

This Practice Note has been prepared in accordance with standard IPENZ Practice Note procedures. This included reporting on progress to the EPAC, peer review and general membership review. The review and reporting process ensures the delivery of a robust, good-practice technical document. While the lead author and other contributors have made every effort to present a carefully considered Practice Note based on New Zealand professional practice, as well as consultation with the wider industry, they accept that what constitutes good practice may alter over time following changes in knowledge, technology and legislation. They also acknowledge that differing interpretations of relevant legislation and regulations are possible. Therefore, users of the information provided need to confirm with the relevant authorities that their specific requirements are being met.

CONTENTS

PREFACE	I	3.4 Building Act	11
PRACTICE NOTE DEVELOPMENT	II	3.4.1 Overview	11
CONTENTS	III	3.4.2 Tank and pond definition	11
GLOSSARY	VII	3.4.3 Building Consent exemptions for tanks and ponds	11
PART 1: DESIGN AND CONSTRUCTION PRINCIPLES	1	3.4.4 Dam definition	12
1. INTRODUCTION	2	3.4.5 Retaining walls	14
1.1 FDE management	2	3.4.6 Building Code and industrial liquid wastes	15
1.2 FDE ponds	2	3.5 Historic Places Act	15
1.3 Types of FDE ponds	2	3.6 Regulatory requirements overview	16
2. BACKGROUND	3	4. SITE INVESTIGATIONS	18
2.1 What is good practice?	3	4.1 Investigation purpose: an overview	18
2.2 Why are FDE ponds necessary?	3	4.1.1 New ponds	18
2.2.1 Regional council requirements	3	4.1.2 Existing ponds	18
2.2.2 Environmental protection	3	4.2 Soil properties	18
2.3 Roles and responsibilities	4	4.3 Siting a new pond	19
3. LEGISLATION AND REGULATIONS	5	4.4 Field investigation steps	20
3.1 Introduction	5	4.4.1 Groundwater	21
3.2 The Health and Safety at Work Act 2015 (HSWA)	5	5. FDE SYSTEM ELEMENTS	22
3.2.1 Controlling health and safety risks	6	5.1 Introduction	22
3.2.2 Typical FDE storage hazards and controls	7	5.2 Types of ponds	22
3.3 Resource Management Act	8	5.3 Effluent treatment design	22
3.3.1 FDE and the Resource Management Act	8	5.3.1 Anaerobic and aerobic ponds	22
3.3.2 Regional council requirements for FDE ponds	9	5.3.2 Effluent ponds as storage	23
3.3.3 Regional council responsibilities for FDE ponds	10	5.4 Solids management	23
3.3.4 District council responsibilities	10	5.4.1 Solids removal	23
3.3.5 Other council responsibilities	10	5.4.2 Mechanical separation	23
		5.4.3 Non-mechanical separation	23
		5.5 Effluent irrigation	24
		5.6 Pond sizing	26
		5.6.1 Deferred irrigation storage	26
		5.6.2 Retention time	27
		5.6.3 Effluent production rates	27
		5.7 Pond geometric design	27
		5.7.1 Geometry	27
		5.7.2 Batter slopes	28
		5.7.3 Spillways, pipes, and filter collars	28

5.8 Solids management design	29	8. OPERATION AND MAINTENANCE	42
5.8.1 Clean-out design	29	8.1 Introduction	42
5.8.2 Liner protection for mechanical cleanout	29	8.2 As-built plans	42
5.8.3 Sludge beds, bunkers, and draining pads	30	8.3 Operation manual	42
5.9 Liners	30	8.4 Inspections	42
5.9.1 Liner options	30	8.5 Pond level monitoring	43
5.9.2 Concrete liners	31	8.6 Pond level testing	43
5.10 Pond performance considerations	32	8.6.1 Simple pond level test	44
5.10.1 Drainage control and leak detection systems	32	8.6.2 Pond Drop Test (PDT)	44
5.10.2 Gas drainage	33	8.7 Leak response	46
5.10.3 Health and safety requirements	33	8.8 System operation	46
6. DESIGN AND CONSTRUCTION	34	8.8.1 Treatment levels	46
6.1 Introduction	34	8.8.2 Desludging	46
6.2 Drawings and specifications	34	8.8.3 Odours	46
6.3 Construction monitoring	34	8.9 Existing FDE ponds	47
6.4 Effects of works on others	35	9. FORMS OF CONTRACT	48
6.5 Underground services	35	9.1 Scope of work and engagement	48
6.6 Drainage control	35	9.2 Contractor selection	48
6.7 Construction equipment	35	9.3 Contractor engagement	49
6.8 Compaction	36	PART 2: CLAY LINERS FOR PONDS	50
6.8.1 Compaction Theory	36	1. INTRODUCTION	51
6.8.2 Compaction testing: embankments	37	1.1 Introduction	51
6.8.3 Compaction trial	38	2. DESIGN CALCULATIONS	52
6.8.4 Construction good practice	38	2.1 Hydraulic conductivity	52
6.9 Exposed batters	39	2.2 Seepage calculation	52
6.10 Fences and gates	39	2.3 Flow and seepage with varying hydraulic conductivity	53
7. CERTIFICATION	40	3. INVESTIGATION AND TESTING	56
7.1 Certification under the Building Act	40	3.1 Investigation	56
7.1.1 Certification by regional councils	40	3.2 Laboratory testing	56
7.1.2 Producer statements	40	3.2.1 Particle size distribution	58
7.2 Certification of construction	41	3.2.2 Plasticity limits	58
7.3 Certification under the RMA by regional councils	41	3.2.3 Linear shrinkage	59
		3.2.4 Dispersion	60
		3.2.5 Permeability	60
		3.2.6 Compaction	60

4. LINER DESIGN	64	3. INSTALLATION	84
4.1 Slope angles	64	3.1 Experienced installers	84
4.2 Thickness of liner	65	3.2 Subgrade preparation	84
4.3 <i>In situ</i> clay ponds	65	3.3 Anchor trenches	84
4.4 Clay liner protection	65	3.4 Geosynthetic Clay Liner (GCL)	85
4.5 Under drainage	66	3.5 Safety	85
4.6 Soil treatment using bentonite	67	3.6 Groundwater and drainage	85
4.6.1 Bentonite layers	68	3.7 Gas venting	85
5. CONSTRUCTION METHODODOLOGY	69	3.8 Drainage and venting system design	86
5.1 Compaction equipment	69	3.9 Penetrations	86
5.2 Control of water	69	3.10 Stirrers	86
6. QUALITY ASSURANCE	71	3.11 Quality Assurance and warranties	87
6.1 Compaction trial	71	4. SUMMARY	88
6.2 Site testing	71	PART 4: PONDS AND TANKS ON PEAT	89
6.3 Seepage testing	73	1. INTRODUCTION	90
6.3.1 Pond level testing	73	1.1 Purpose	90
6.3.2 Permeability testing on clay core	73	1.2 What is peat?	90
6.4 Records and sign-offs	74	1.3 Why is peat a challenge?	92
PART 3: GEOMEMBRANE (SYNTHETIC LINER) SELECTION	75	2. ENGINEERING PROPERTIES OF PEAT	94
1. INTRODUCTION	76	2.1 Engineering issues with construction on peat	94
1.1 Geomembranes	76	2.2 Bearing capacity failure	94
2. GEOMEMBRANES	78	2.3 Excessive settlement	95
2.1 Types of geomembranes	78	2.4 Shallow groundwater table	95
2.2 Geosynthetic Research Institute (GRI) specifications	78	2.5 Gas collection	96
2.2.1 Warranty and Performance	80	3. SETTLEMENT	97
2.3 Geomembrane selection by attributes	81	3.1 Managing settlement	97
		3.2 Pond bank settlement	98
		3.3 Tank settlement	99
		3.4 Settlement during use	99

4. GROUND INVESTIGATION, DEPTHS AND METHODS	100	6. CONSTRUCTION	120
4.1 Scope of investigation	100	6.1 Bund Construction Testing	120
4.2 Depth of investigation	100	6.2 Health and Safety	121
4.3 Methods	100	REFERENCES	123
4.3.1 Cone Penetrometers (CPT)	100	APPENDIX A - REGULATORY CHECKLIST	128
4.3.2 Boreholes	103	DISCLAIMER	133
5. DESIGN PROCESS AND CONSIDERATIONS	104	COPYRIGHT	133
5.1 Cost and risk assessment	104		
5.2 Design process steps	105		
6. SUMMARY	106		
7. ACKNOWLEDGEMENTS	108		
PONDS AND TANKS ON PEAT CASE STUDY - HAURAKI MARINE CLAYS	109		
1. INTRODUCTION	110		
2. GEOLOGY	112		
2.1 Hauraki 'Marine' Clays	112		
2.2 Suitable Locations	113		
2.3 Profile Variability	113		
3. ENGINEERING PROPERTIES	115		
3.1 Shear Strength	115		
3.2 Cracking	115		
3.3 Permeability	115		
3.4 Settlement	115		
4. INVESTIGATIONS	116		
4.1 Site Investigations	116		
4.2 Laboratory Testing	117		
5. DESIGN	118		
5.1 Bunding	118		
5.2 Pond Sizing	118		
5.3 Additional Design Recommendations	118		

GLOSSARY

BA	Building Act	NZFSA	New Zealand Food Safety Authority
BCA	Building Consent Authority	NZGS	New Zealand Geotechnical Society
BOD	Biological Oxygen Demand (a measure of degradable organic matter content)	NZHPT	New Zealand Historic Places Trust
CCL	Compacted Clay Liner	NZS	New Zealand Standard(s)
CPEng	Chartered Professional Engineer	OMC	Optimum Moisture Content (of soil)
CPT	Cone Penetrometer Testing	PDT	Pond Drop Test
DC	District Council	PI	Plasticity Index
DD	Dry Density	PL	Plastic Limit
DD/WC	Dry Density/Water Content	PN	Practice Note
DESC	Dairy Effluent Storage Calculator (Massey University and Horizons Regional Council)	Principal	Client or farm owner
EPDM	Ethylene Propylene Diene Monomer (Rubber)	PS	Producer Statement
FDE	Farm Dairy Effluent	QA	Quality Assurance
FML	Flexible Membrane Liners	RA	Regional Authority
fPP	flexible Polypropylene	RC	Regional Council
Freeboard	Volume (or height) above maximum effluent design level in pond	RMA	Resource Management Act
GCL	Geosynthetic Clay Liner	SV	Shear Vane
GRI	Geosynthetic Research Institute	TA	Territorial Authority
HDPE	High Density Polyethylene (Plastic)	UV	Ultra Violet
HSWA	Health and Safety at Work Act 2015	WC	Water Content
IANZ	International Accreditation NZ		
IPENZ	Institution of Professional Engineers of New Zealand		
LA	Local Authority		
LDS	Leakage Detection System		
LL	Liquid Limit		
LS	Linear Shrinkage		
MBIE	Ministry of Business, Innovation and Employment		
MC	Moisture Content		
MDD	Maximum Dry Density (soil)		
NDM	Nuclear Density Meter		

PART 1
**DESIGN AND CONSTRUCTION
PRINCIPLES**

1. INTRODUCTION

1.1 FDE MANAGEMENT

Farm Dairy Effluent (FDE) is the collective term for dairy cow urine, faeces, and wash-down water. It varies in volume and composition and reflects many factors, including the number of cows milked, feed type, shed practices, wash-down methods, weather, and the time of year.

During the milking process, it is estimated that around 10 per cent of a cow's daily urine and faeces is excreted in the dairy shed or yard. The FDE may also include material collected from laneways, feed pads, wintering pads, silage stacks, and stock underpasses. Generally, the FDE captured from these sources is retained in a temporary containment facility and irrigated to pasture. However, there are times when soil conditions are not suitable for FDE irrigation and its deferred storage is required.

1.2 FDE PONDS

Farm Dairy Effluent ponds are primarily constructed to provide temporary deferred storage and treatment for effluent generated from dairy milking sheds. They are also used to store and treat leachate and effluent generated from silage stacks, wintering pads, barns, and farm infrastructure such as lanes and stock underpasses.

The purpose of an FDE pond is to provide temporary storage and treatment of effluent during periods when soil conditions are not suitable for effluent irrigation. Scientific research on the environmental effects of effluent irrigation highlights the importance of effluent storage as contingency during these periods. Effluent storage is particularly important in wetter regions of New Zealand where there are extensive mole and tile drainage networks, high water tables, and higher drainage-risk soil types where nutrient leaching to groundwater or waterways could occur.

Agricultural research has identified the value in providing increased on-farm effluent storage. However, a lack of national guidance has seen the development of FDE ponds which are inappropriately designed, sited and constructed.

This Practice Note highlights the critical elements of good FDE pond design and construction. It also considers FDE pond operation and maintenance, explores the definition of ponds, tanks, and "small" dams, and outlines the Building and Resource Consents required for their construction.

1.3 TYPES OF FDE PONDS

Farm Dairy Effluent ponds range in their size, shape, construction materials and capacity. Earthen embankment ponds are formed from compacted earth material with a Compacted Clay Liner (CCL) or geomembranes (also known as synthetic liners), while concrete ponds may be formed from a series of concrete cast *in situ* or precast panels or sprayed (shotcrete) concrete. There are also several other types of FDE containment structures such as proprietary concrete and synthetic lined tanks.

2. BACKGROUND

2.1 WHAT IS GOOD PRACTICE?

Good practice may be defined as “a benchmark that seeks to meet industry expectations and typically exceeds minimum compliance requirements”.

To meet the key operational good-practice outcomes, FDE designs must:

- Meet Regional Council and Building Act rules and consent conditions
- Comply with the Health and Safety at Work Act 2015
- Include a pond liner of a sufficiently low seepage rate to minimise adverse environmental effects, including infiltration to groundwater
- Be structurally sound
- Allow for ongoing operation and maintenance and be appropriately sized for the volume of on-site effluent
- Meet its intended use and life span’s durability and serviceability requirements
- Provide a clear documentation trail for accountability of the services and components incorporated into the works by contractors and suppliers.

2.2 WHY ARE FDE PONDS NECESSARY?

2.2.1 Regional council requirements

Regional councils and unitary authorities impose a range of regulatory requirements on the discharge of effluent (to air, land, or water). The purpose of these regulations is to avoid, remedy, and mitigate the adverse effects on the environment.

The requirement for FDE ponds is driven by most councils under the Resource Management Act 1991 (RMA). Aspects of FDE pond construction are also regulated by Regional Council’s and District Councils under both the RMA and the Building Act. There is variability in the regulatory requirements relating to FDE ponds throughout New Zealand so farm owners and designers must familiarise themselves with both local and regional relevant regulations.

2.2.2 Environmental protection

Using a FDE pond to process and store effluent enables farmers to manage the effluent’s discharge. The irrigation method adopted determines the rate, depth, and evenness of application and therefore the likelihood of environmental contamination; however, this is outside the scope of this Practice Note.

Regional Councils advocate that good practice is to discharge effluent to land when soil conditions are appropriate. Appropriate conditions are those where soil moisture is at a sufficiently low level for the contaminants in the effluent to:

- Be utilised by the soil’s biological system
- Not move to surface water through overland or subsurface flow
- Not infiltrate to groundwater

Any ponding or run-off has the potential to have adverse effects on the environment, such as excessive nutrients and pathogens entering groundwater and surface waterways.

All FDE structures including ponds, sumps, tanks, dams, as well as the pipes or channels between them must provide a contained system that prevents FDE leakage.

2.3 ROLES AND RESPONSIBILITIES

In understanding the roles and responsibilities associated with FDE pond design and construction, it is important to identify the various parties and their roles. Table 2.1 summarises these.

Table 2.1: Roles and Responsibilities

Farm owner/client	The farm owner/client is the person who meets the costs, makes the decisions, and in most cases, is the owner of the land on which the pond sits. They are generally the 'owner' of any resource consent for the pond and are responsible for ensuring their pond is designed, constructed, and operated in a safe and legally compliant manner.
Regional Council	The Regional Council has the jurisdiction to determine the rules for FDE pond construction and operation under the RMA. This includes setting the pond liner's allowable permeability, the pond's volume, and its separation distance from features such as waterways. It is also responsible for administering Building Act requirements where a dam exists (including all aspects of the dam structure's physical integrity and mechanical safety).
District Council	The District Council has the jurisdiction to dictate the rules relating to the FDE pond's amenity aspects under the RMA. District plans may specify separation requirements (from neighbours, roads, public amenities, other), either as conditions of a Permitted Activity or as an indication of a requirement for a Resource Consent. The District Council is also responsible for administering the Building Act and its related requirements for structures other than dams.
Designer	<p>Either a Chartered Professional Engineer competent in the field of effluent structures design and construction or an alternative person that has been assessed by a Regional Councils to be competent in the field of effluent structures design and construction.</p> <p>Chartered Professional Engineers (CPEng) are bound by the CPEng Code of Ethical Conduct.</p>
Person carrying out Construction Monitoring	<p>Either a Chartered Professional Engineer competent in the field of effluent structures design, construction monitoring and construction or an alternative person that has been assessed by a Regional Councils to be competent in the field of effluent structures design, construction monitoring and construction.</p> <p>In many circumstances the designer will also be the person engaged to carry out construction monitoring.</p>
Contractors	Contractors with a proven track record in FDE pond construction and Quality Assurance procedures in place. Contractors take instruction from the designer, and the farm owner/client when involved, to undertake earthworks and co-ordinate with equipment and service suppliers to construct the pond.
Equipment and service suppliers	Suppliers of irrigation equipment, pond excavation services, suppliers and installers of liners, pumps, and machinery.

3. LEGISLATION AND REGULATIONS

3.1 INTRODUCTION

This section sets out the legislation and regulations that must be considered when designing and constructing an FDE pond. While many of the statutes and regulations relate to design, others simply relate to the presence of a pond or tank.

The Resource Consent requirements for FDE ponds in New Zealand depend on which Regional Council, District Councils, or unitary authority the FDE pond is located within. These organisations are also known as Building Consent Authorities (BCAs).

The Building Consent requirements required by the Building Act are intended to be consistently applied across the country. Even when consent is not required. Building Code performance requirements and Permitted Activity standards in regional and district plans must be met and adverse effects on the environment minimised.

3.2 THE HEALTH AND SAFETY AT WORK ACT 2015 (HSWA)

The Health and Safety at Work Act 2015 (HSWA) is New Zealand's workplace health and safety law. It introduces new responsibilities for managing work-related risks that could cause serious injury, illness or death. The HSWA recognises that all parties need to work together to improve health and safety performance. Organisations and individuals all have a role to play in safe behaviours and managing work-related risks.

HSWA requirements relate to the whole life cycle of containment facilities. Farmers, contractors, designers, manufacturers and suppliers all have a role to play in identifying current and future hazards and managing the associated risks.

The design, manufacture, supply and installation of containment facilities are known as "upstream" activities. Upstream businesses and individuals are responsible for ensuring that the products and services they provide do not create health and safety risks. A preventative approach can be taken during the design and construction phases to eliminate or minimise risks to health and safety before they occur.

Significant hazards associated with farm dairy effluent ponds and tanks are:

- Staff, children and animals falling into ponds
- Poor environmental hygiene
- Increased risk of slips, trips and falls
- Exposed moving parts of effluent pumps
- High pressure hoses and high volume flood washing
- Manure gases
- Increased disease risk from flies and mosquitoes.

Between 2009 and 2014, three deaths occurred during maintenance of pumps fixed to pontoons floating on dairy farm effluent ponds. Twice dairy farm workers drowned when pontoons capsized, trapping them underneath. Another worker was crushed while working on a floating effluent pontoon which became unstable.

Falling into ponds is a critical risk for FDE systems and should be addressed as a priority hazard during design and construction.

The relevant hazards may be present during any number of related processes below:

- Handling
- Storage
- Construction
- Operation
- Cleaning, maintenance and repair
- Exposure of people in the vicinity
- Eventual demolition and disposal
- Disasters.

It is important that a wide range of scenarios are considered to come up with the best measures to manage health and safety risks for FDE containment systems.

Containment failure hazards are best addressed by farm owners ensuring design and construction is undertaken with competent advice to ensure that all “practicable steps” have been taken to mitigate the identified risks.

Investigations

Investigations into breaches of the HSWA are carried out by WorkSafe New Zealand and may lead to enforcement activities.

3.2.1 Controlling health and safety risks

The HSWA requires hazards to be identified and then controlled according to the risks they present. Risks should be controlled in a top down manner via the hierarchy shown in Figure 3.1, with the most effective measures at the top.

Figure 3.1: Hierarchy of Controls

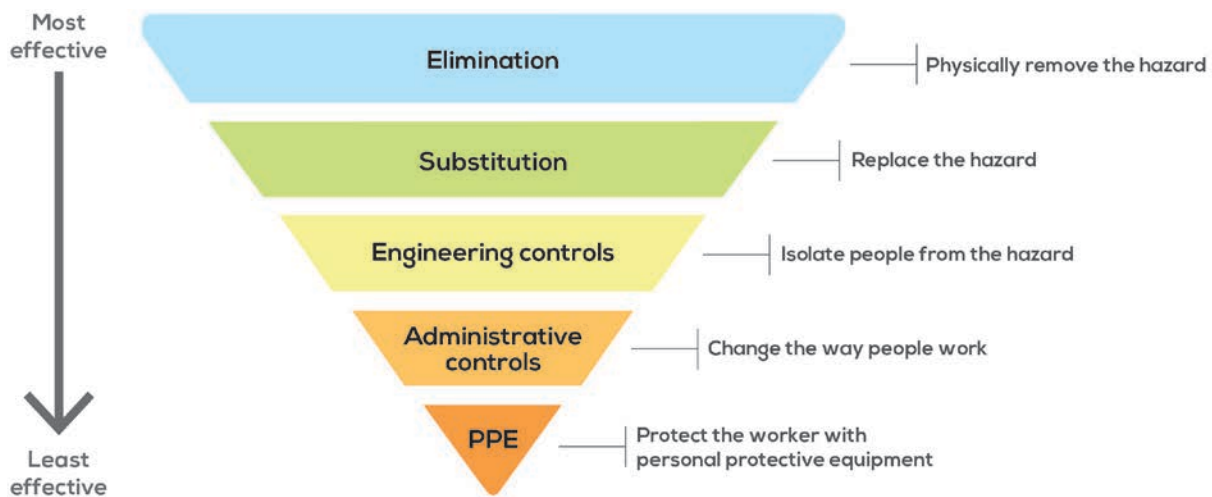

The risk based approach to managing hazards is explained in more detail in IPENZ *Practice Note 27*.

3.2.2 Typical FDE storage hazards and controls

Specific health and safety measures for FDE containment systems are presented below. For further guidance on identification of hazards and their mitigation refer to *Practice Note 27*, Part 1, section 2.

Location

When building a new effluent system, or upgrading your current system, safety should be incorporated during the design stage. Effluent ponds should be located as far from other farm activities and waterways as possible to reduce overall risks. If pumps can be placed away from the pond several risks are eliminated and this also minimises the need to access the pond for maintenance.

Fences and Gates

Fencing FDE containment facilities is required under the farm's health and safety policy. The client/farm owner should decide what level of fencing is required based on their health and safety risk assessment.

The appropriate type and extent of fencing required for each farm will vary and be dependent on the hazard risks identified at the site. Where a site contains hazards, which might attract the unauthorized or unexpected entry of the public, children, or wandering animals (both small and large), then the hazard needs to be fully enclosed to restrict access. At the very least, a secure five-wire fence, preferably with netting and an electric fence 'hot wire' should be constructed. In some locations, a higher fence such as deer fencing will be appropriate.

For effective fence placements, things to consider include tractor/trailor access to empty sludge beds, allowing safe access to pumps and secure fencing to protect not only the pond but the pump sheds and ancillary equipment.

Additional personnel fencing directly surrounding the pond will prevent slips and falls by farm workers into the pond.

To provide greater security around the site, gates that lead into more hazardous areas such as effluent ponds, must have lockable gates. Such areas should only be accessible to those with the authority to enter and are aware of the farm's specific safety procedures.

The Fencing of Swimming Pools Act 1987 requirements do not apply to FDE storage ponds as the ponds are not intended for swimming.

Pontoons

Working on a floating pontoon is a significant hazard, as there is a risk of capsize or partial capsize of the pontoon, and a risk of drowning should the worker fall into the effluent. If possible, do not work on top of a floating effluent pontoon. Consider options such as:

- Removing the pontoon from the pond for service
- Securing the pontoon at the side of the pond
- Carrying out servicing when the pond level is low and capsize is therefore not possible
- Fit automatic greasing components to reduce the frequency at which access is required.

Pontoons should be fitted with a suitable lifting point so they may be lifted from the effluent pond. The lifting device must be of sufficient weight, power, and stability to safely lift the pontoon. The lift point should be designed so that a person does not need to access the pontoon to attach the pontoon to a lifting device.

In some cases, it may be impractical for pontoons to be removed from the pond for general servicing of the pump and stirrer. Work should only be allowed on top of a floating pontoon when all other options have been assessed and are clearly impracticable.

If work is to be conducted from on top of a floating pontoon, it must be stable and unable to capsize and there must be safe access to it. Safe access would typically require a one-metre-high handrail comprising a top rail and mid-rail fitted to the perimeter of the working area of the platform to prevent a fall from the pontoon or access way. Anchor points can be provided to increase stability.

Manufacturers, suppliers and people who carry out modifications to effluent pumping pontoons must ensure that pontoons are stable and safe to work from. They must ensure that farmers are provided clear information regarding the safety precautions and loading capacity for pontoons.

Farmers must ensure that they are fully aware of the safe loading limits and related safety precautions for accessing and maintaining pontoons in service on their property. If the pontoon is modified in any way, the farmer must ascertain whether such modifications have impacted on the safe loading capacity and safe access requirements.

Working Around Water

Working around water, including servicing of pumps and stirrers on ponds, requires a minimum of two people, including one person available always for support and/or for rescue if problems arise. Lifejackets must be provided and worn if out on a pontoon or working around deep water.

Consideration must be given to rescue protocols if someone falls into a FDE pond.

Options include ladders (that can be realistically reached), ropes and life rings/preservers.

Operating Procedures

Operating procedures must be developed for both routine and emergency scenarios. The best procedures are those that have been developed in collaboration with working staff. These procedures need to be written down and include a requirement that two people must be on hand when accessing the pond (one to provide backup assistance). Ensure procedures are practised, kept up to date, and communicated to all relevant people.

Signage

Warning signs alert everyone to the hazards. The signs should specify access controls, for example, two people must be present when accessing the pond, or authorised access only.

3.3 RESOURCE MANAGEMENT ACT

3.3.1 FDE and the Resource Management Act

The Resource Management Act 1991 (RMA) contains various duties and restrictions in relation to the use of land and water, and to the discharge of contaminants into the environment. The RMA provides a legislative framework, under which regional and district councils are responsible for achieving sustainable management within their geographical area. Primarily this is achieved through regulations as part of the regional and district plans.

Many farming activities are permitted activities and do not need to be covered by specific resource consents. Increasingly however, dairy effluent consents are required as well and pond consents. Advice from the relevant regional or district council, or a resource management professional, should be sought.

Regional Councils are responsible, under the RMA, for FDE ponds. Table 3.1 outlines the relevant RMA sections.

Table 3.1: FDE and the RMA

Section 9	This section places restrictions on certain uses of land. No person may use land in a manner that contravenes a regional or district rule, in which case a resource consent is likely to be required. Typically, FDE ponds may require resource consent for the activity of effluent storage itself, earthworks for pond construction, large storage volumes or locational constraints (separation to neighbours).
Section 14	This section outlines the restrictions relating to water. No person may take, use, dam, or divert water without appropriate plan or consent provision. However, FDE ponds built out of and away from natural watercourses will not involve damming water in the sense intended by the RMA.
Section 15	This section states that no person may discharge any contaminant into water, or onto land, in circumstances which may result in contaminants entering water; unless the discharge is expressly allowed by a rule in a regional plan or Resource Consent.
Note: Agricultural effluent ponds are also administered by some Regional Councils under section 9 of the RMA (restrictions on use of land).	

Regional councils regulate certain aspects of FDE pond construction and operation through their plans and/or consent process. The primary purpose of this is to protect surface water and groundwater from potential of FDE contamination.



2,000m³ precast concrete tank

3.3.2 Regional council requirements for FDE ponds

Regional councils in New Zealand, manage natural resources, including lakes, rivers, air, coastal and soil resources. There are also five unitary authorities in New Zealand, who play both the role of regional council and district council.

There is wide variation between regional plan specifications for FDE ponds. Councils often consider the following in their internal guidance documents:

- A pond's volumetric capacity and slope of batters
- The pond liner's maximum leakage rate (or seepage rate) at full hydraulic loading
- The pond's spatial separation from bores, wetlands, waterways, and waahi tapu
- Design and construction sign-off protocols.

Some regional councils (RCs) require land use consents for ponds.

3.3.3 Regional council responsibilities for FDE ponds

The RMA and regional plan requirements and specifications vary in relation to directing FDE pond management and construction.

Much of the RC guidance concerns the impact of FDE pond discharges on the environment. The RC provisions are only legally binding if they are incorporated into a consent and have been accepted by the parties involved. This differs to requirements in a regional plan which have been through a public process prior to being adopted, and are therefore legally binding.

The Regulatory Checklist in Appendix A indicates the rule variation between RCs for effluent management at the time the rules became operative.

3.3.4 District council responsibilities

District and city councils in New Zealand, control the use, development and protection of land and how the uses can affect the environment.

Generally, one district plan is produced for each district or city council. Like regional plans, each district plan must contain objectives for the district, policies to implement these objectives and rules to implement the policies. They may include other matters such as non-regulatory methods and expected environmental results.

The construction and operation of FDE ponds is frequently, but not always, a permitted activity by district councils, whether specifically or by default. Separation distances from roads, houses or property boundaries are often specified, and these can differ from the separations required by regional councils depending on zoning and sensitivity of the surrounding environment. When considering the construction of FDE ponds, not only should the activity itself be assessed against the district plan with regards to location, distance and storage volume, but it will also be necessary to ensure that the earthworks required for construction are also authorised.

Under section 9 of the RMA, any land use is permitted unless stated otherwise in a regional or district plan. Care is needed to ensure FDE ponds are allowed (that is, a Permitted Activity) in the zones involved, so in addition to regional plans, the district plan should always be consulted for certainty.

The plans may also include performance standards that must be maintained.

3.3.5 Other council responsibilities

Within New Zealand's regulatory framework Councils are responsible for ensuring regulations are administered and complied with.

The National Environmental Standard for Assessing and Managing Contaminants in Soil to Protect Human Health (NESCS) is relevant to the siting of FDE ponds. The NESCS apply to land if it is used, or has been used, or is more likely than not to have been used, for one of the activities or industries listed on the Hazardous Activities and Industries List (HAIL) which are considered likely to cause land contamination. The HAIL can be found on the Ministry for the Environment's website or at the local council.

Further comment is contained in *Practice Note 27*, Part 1, section 4.0

3.4 BUILDING ACT

3.4.1 Overview

This section focusses on relevant parts of the Building Act as it relates specifically to tanks and ponds.

Practice Note 27 Part 1 section 5 provides fuller guidance on the Building Act, the Building Code and Building Consents and readers should also refer to this document.

Farm Dairy Effluent can be contained in a variety of structures including tanks, pits, dams, and ponds. It is therefore important for the FDE system designer to have some understanding of the Building Act as it relates to both Building Consent and Building Code requirements. The Building Act provides a process for regulating the design and construction of structures and is generally managed by District Council's as the Building Consent Authority (BCA).

FDE ponds constructed in or above the ground with compacted soil do not generally require Building Consents.

3.4.2 Tank and pond definition

While a 'tank' is referenced in the Building Code, it is not defined. The term 'pond' is not referenced at all. It is generally accepted that some effluent structures, for example, concrete lined ponds, should be classified as tanks. Tanks in the Building Act context may also refer to pools, sumps, some ponds, and some other containment structures. Presently Building Consent requirements under the Building Act for tanks and alterations to existing tanks attract varied interpretations around the country.

As the definition of a tank and a pond is not defined with regulation, the following definitions are used for this Practice Note. It should be noted these definitions do not have any formal recognition.

Tank:	Is constructed of man-made materials such as concrete, steel, plastic, or another product(s). Its purpose is to retain and store effluent fluids and semi-solids. The tank materials are used as the structural elements to retain the fluid. A tank typically has vertical sides and may have a lid.
Pond:	Is constructed of compacted soil or excavated into the existing ground, or a combination of both these methods, to retain and store effluent fluids and semi-solids. Ponds may have a liner installed to prevent from leakage. The earthen materials are used to provide the structural elements for confinement and have side slopes of less than 45 degrees.

3.4.3 Building Consent exemptions for tanks and ponds

Using the above definition of effluent tanks, the following guidance is given for qualifying for a Building Consent exemption under the Building Act. The Schedule 1 exemption referred to in Table 3.2 means all tanks 35 m^3 (35,000 L) built on or in the ground do not require a Building Consent, but all tanks >math>35 \text{ m}^3</math> do.

Table 3.2: Building Consent Exemption – Excerpt from Schedule 1, Part 1 Exempted Building Work, Section 23(g)

23 Tanks and pools

“Building work in connection with a tank or pool and any structure in support of the tank or pool, including any tank or pool that is part of any other building for which a building consent is required, that –
(g) does not exceed 35,000 L capacity and is supported directly by ground.”

An exemption from a Building Consent for tanks >35 m³ however is possible under section 2 as described in Table 3.3.

Table 3.3: Building Consent Exemption – Schedule 1, Part 1 Exempted Building Work, Section 2

2 Territorial and regional authority discretionary exemptions

“Any building work in respect of which the territorial authority or regional authority considers that a building consent is not necessary for the purposes of this Act because the authority considers that –

- (a) the completed building work is likely to comply with the Building Code; or
- (b) if the completed building work does not comply with the Building Code, it is unlikely to endanger people or any building, whether on the same land or on other property.”

This exemption allows a BCA to exempt proposed building work in the circumstances specified at the council’s discretion. It is based on the council’s own assessment of the risk of building work not being carried out per the Building Code, or of endangering people or property.

3.4.4 Dam definition

With respect to the Building Act, a dam is the physical structure that can hold back water above ground level. Table 3.4 provides the legal definition of a dam. A pond can exist without a dam, in which case the maximum water level would be below ground level. As soon as the water level rises above the ground surface, the containment structure is described as a dam. The dam is not the whole containment structure, but only the physical barrier where the water level exists above ground level.

Many ponds are essentially pits in the ground, with the placement and compaction of the cut material forming an embankment around the pond perimeter. When the pond is filled up to, or lower than, the lowest elevation of the surrounding ground, no damming will have occurred. However, if the fluid level rises above the lowest level of the surrounding ground, so the surrounding wall provides a barrier, the surrounding wall will be functioning as a dam.

Table 3.4: Dam and Large Dam Definition, Building Act 2004, Part 1, Subpart 2 – Interpretation, section 7

7 Interpretation

“dam –

- (a) means an artificial barrier, and its appurtenant structures, that –
 - (i) is constructed to hold back water or other fluid under constant pressure so as to form a reservoir; and
 - (ii) is used for the storage, control, or diversion of water or other fluid; and
- (b) includes –
 - (i) a flood control dam; and
 - (ii) a natural feature that has been significantly modified to function as a dam
 - (iii) a canal; but
- (c) does not include a stopbank designed to control floodwaters”

“large dam –

means a dam that has a height of 4 or more metres and holds 20 000 or more cubic metres volume of water or other fluid”

Given that it would be rare for an effluent pond to meet the large dam criteria, large dam FDE ponds are not further explored in this Practice Note.

In terms of the Building Act, dam management is delegated to Regional Councils, rather than District Council. The Regional Councils' concern focuses on the potential for the dam structure to fail; and the consequences if they do fail.

Table 3.5 shows FDE ponds can fall into one of three categories. They can be generally described as either “not a dam”, a “dam”, or a “large dam”.

Table 3.5: Categories of FDE Ponds

Not a dam	If a pond is constructed by excavating a pit in the ground, and does not have an embankment constructed to allow the fluid to rise to a greater height than that of the surrounding land, then the pond is not confined. It is therefore not a dam.
Dam	If a pond is constructed to form a reservoir of fluid then the pond is defined by the Building Act as a dam, if it has either: (a) a height of <4 m and holds <20,000 cubic metres; or (b) a height of ≥4 m and holds <20,000 cubic metres; or (c) a height of <4 m and holds ≥20,000 cubic metres
Large dam	A large dam means a dam that has a height ≥4 m and holds ≥20,000 cubic metres of water or other fluid.

Table 3.6: Dam height defined (From the Building Act 2004 Part 2, Subpart 7, Section 133B)

<p>The height of a dam is defined as follows:</p> <p>133B Measurement of dams</p> <p>For the purposes of this Act and any regulations made under it, the height of a dam is the vertical distance from the crest of the dam and must be measured –</p> <p>(a) in the case of a dam across a stream, from the natural bed of the stream at the lowest downstream outside limit of the dam; and</p> <p>(b) in the case of a dam not across a stream, from the lowest elevation at the outside limit of the dam; and</p> <p>(c) in the case of a canal, from the invert of the canal.</p>
--

The Building Code sets out performance standards that building work must meet, and covers aspects such as structural stability and durability. The Building Code does not prescribe how building work should be done (i.e., no detailed requirements for design and construction), but states how completed building work, and its components, must perform. This is important when considering constructing a dam, as each dam is unique to its location and environment. A dam, however, should be designed and constructed and maintained in a manner that safeguards people and property from structural failure and throughout its life continues to comply with the Building Code and have a low probability of failure.

Depending on the circumstances, some pond-related structures, such as jetties and floating pontoon structures, may meet the “appurtenant structure” definition described in the Building Act. In these cases, they will be part of a dam. They are also likely to be considered “building work” so must comply with the Building Code.

It is also important to note that while a Building Consent may not be required for a dam, a Resource Consent may be required for the earthworks associated with its construction.

3.4.5 Retaining walls

The Building Act's definition of a retaining wall is interpreted so that if a FDE pond, tank, sump or other retaining wall structure (e.g. constructed of concrete, steel or timber) is not higher than 1.5 m and does not support any load, then it will not require a Building Consent. This decision will probably also depend on the retaining structure's construction, function, depth, and geometry.

If a retaining structure of less than 3 m depth were to be constructed in a rural zone, then it may be exempt from the Building Consent requirement. However, this will only be the case if the design is carried out or reviewed by a Chartered Professional Engineer.

Exemptions for retaining structures are detailed in schedule 1 of the Building Act; refer to Table 3.7.

Throughout New Zealand there are a variety of council consent and enforcement requirements for containment structures. Councils are best placed to clarify and confirm the specific consent requirements in their areas.

Table 3.7: Excerpts from the Building Act, Schedule 1 Building work for which building consent not required

<p>Part 1 Exempted building work</p> <p>20 Retaining walls</p> <p>Building work in connection with a retaining wall that –</p> <ul style="list-style-type: none"> (a) retains not more than 1.5 m depth of ground; and (b) does not support any surcharge or any load additional to the load of that ground (for example, the load of vehicles)." <p>22 Dams (excluding large dams)</p> <p>Building work in connection with a dam that is not a large dam."</p>
<p>Part 3 Building work for which design is carried out or reviewed by chartered professional engineer</p> <p>41 Retaining walls</p> <ul style="list-style-type: none"> (1) Building work in connection with a retaining wall in a rural zone, if – <ul style="list-style-type: none"> (a) the wall retains not more than 3 m depth of ground; and (b) the distance between the wall and any legal boundary or existing building is at least the height of the wall. (c) rural zone means any zone or area (other than a rural residential area) that, in the district plan of the territorial authority in whose district the building work is to be undertaken, is described as a rural zone, rural resource area, or rural environment, or by words of similar meaning.

3.4.6 Building Code and industrial liquid wastes

Section G1 of the Building Code does not specifically define FDE as a hazardous material. Nor is it listed in Table 1 of section G14 as an example of industrial liquid waste.

However, the section on storage facilities (G14.3.2 of the Building Code) does provide some good-practice considerations when designing FDE ponds (refer to Table 3.8).

Table 3.8: Building Code Section G14.3.2: Industrial Liquid Wastes

- “Facilities for the storage, treatment, and disposal of industrial liquid waste must be constructed –
- (a) with adequate capacity for the volume of waste and the frequency of disposal; and
 - (b) with adequate vehicle access for collection if required; and
 - (c) to avoid the likelihood of contamination of any potable water supplies in compliance with Clause G12 “Water supplies”; and
 - (d) to avoid the likelihood of contamination of soils, groundwater, and waterways except as permitted under the Resource Management Act 1991; and
 - (e) from materials that are impervious both to the waste for which disposal is required, and to water; and
 - (f) to avoid the likelihood of blockage and leakage; and
 - (g) to avoid the likelihood of foul air and gases accumulating within or entering into buildings; and
 - (h) to avoid the likelihood of unauthorised access by people; and
 - (i) to permit easy cleaning and maintenance; and
 - (j) to avoid the likelihood of damage from superimposed loads or normal ground movement; and
 - (k) if those facilities are buried underground, to resist hydrostatic uplift pressures.”

These considerations pick up several issues which are covered in other design guidance Practice Notes and Standards, which are crucial for good-practice design. This guidance is available for instance for (a) pond capacity; (e) leakage and is prescribed by Regional Councils; and (h) safety, which is covered by the Health and Safety at Work Act (HSW).

3.5 HISTORIC PLACES ACT

The Historic Places Act 1993 makes it unlawful to destroy, damage, or modify an archaeological site without prior authority from the New Zealand Historic Places Trust (NZHPT). This means any work that may affect an archaeological site requires an authority from the NZHPT before work begins. This may include road works, quarrying, and any other excavation activities related to pond construction. This is the case regardless of whether a Resource or Building Consent has been granted.

As part of their district plan, Territorial Authorities (TAs) prepare maps which include heritage and archaeological sites. These should be checked prior to consent applications being submitted for pond and related earthworks.

If a previously unknown site is uncovered during earthworks, permission from the NZHPT may be needed for the work to continue. For further information on investigating archaeological sites, contact NZHPT or email archaeologist@historic.org.nz

3.6 REGULATORY REQUIREMENTS OVERVIEW

There are potentially four sets of regulatory standards to be met for FDE containment facilities (which include dams, tanks, sumps, pools, and ponds). Up to three of these may involve consent requirements.

While in most situations dams, tanks, and ponds may be constructed without requiring Building Consent, Building Code performance compliance is still required. Furthermore, if the FDE pond or tank design and construction require a Building Consent, then generally only a CPEng has the authority for signing off such work. Whether this is required depends on the BCA's policies.

As an overview, Table 3.9 notes the key regulatory requirements for FDE ponds, while Figure 3.1 outlines consenting and code of compliance requirements. Figure 3.2 provides a schematic regulatory decision flow diagram to help those involved in decision making understand the consent process. The relevant regulatory requirements are summarised in a checklist in Appendix A.

Table 3.9: Regulatory Requirements

Act or Type of Legislation	Possible Requirements	Regulatory Authority
Resource Management Act 1991	Resource Consent for construction/earthworks (if trigger is exceeded) Resource consent for use/discharge Consent for stream diversion	Regional Council
Building Act 2004; Building Code	Consent for construction Consent for tank Dam consent	District and Regional Council or unitary authority
Local government requirements (district plan/RMA)	Land use consent Earthworks/gravel extraction	Local council or unitary authority
Health and Safety at Work Act 2015	Safety during construction Fencing of ponds	WorkSafe New Zealand

Key Points

- Consents required for ponds will depend on whether they are considered a dam or not
- Regional Council and Building Consent requirements can vary
- Tanks may need Building Consents
- Health and safety requirements including fencing and means of escape must be considered
- All ponds must meet the performance requirements of the Building Act.

Figure 3.1: Consenting and Code Compliance Requirements

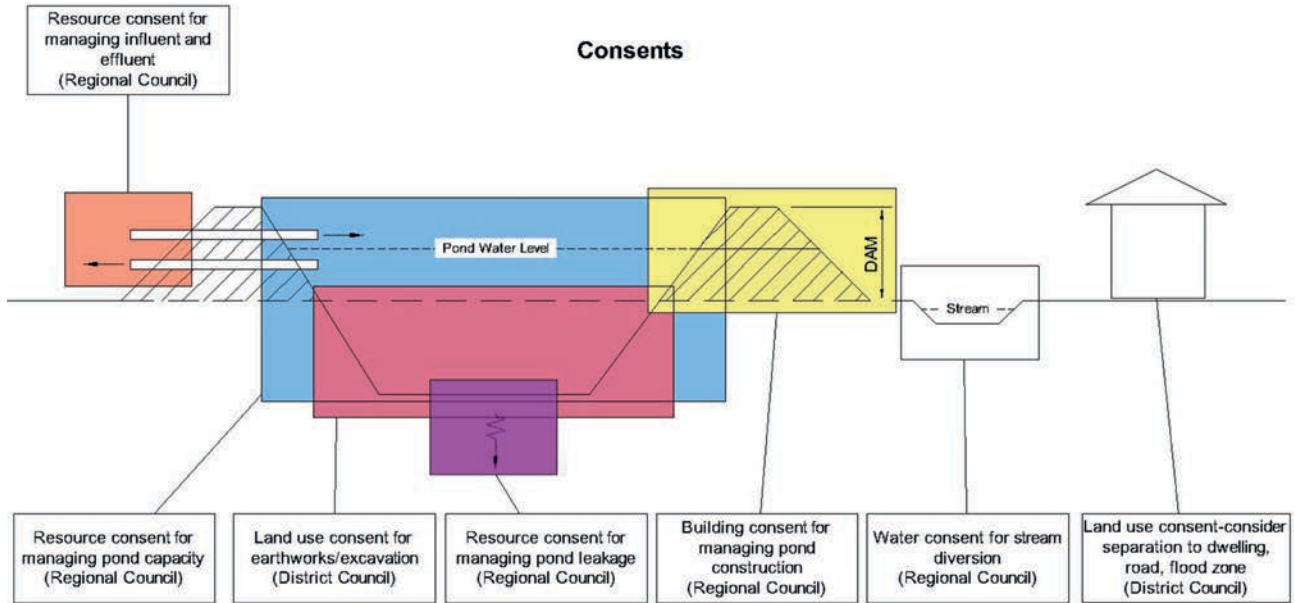
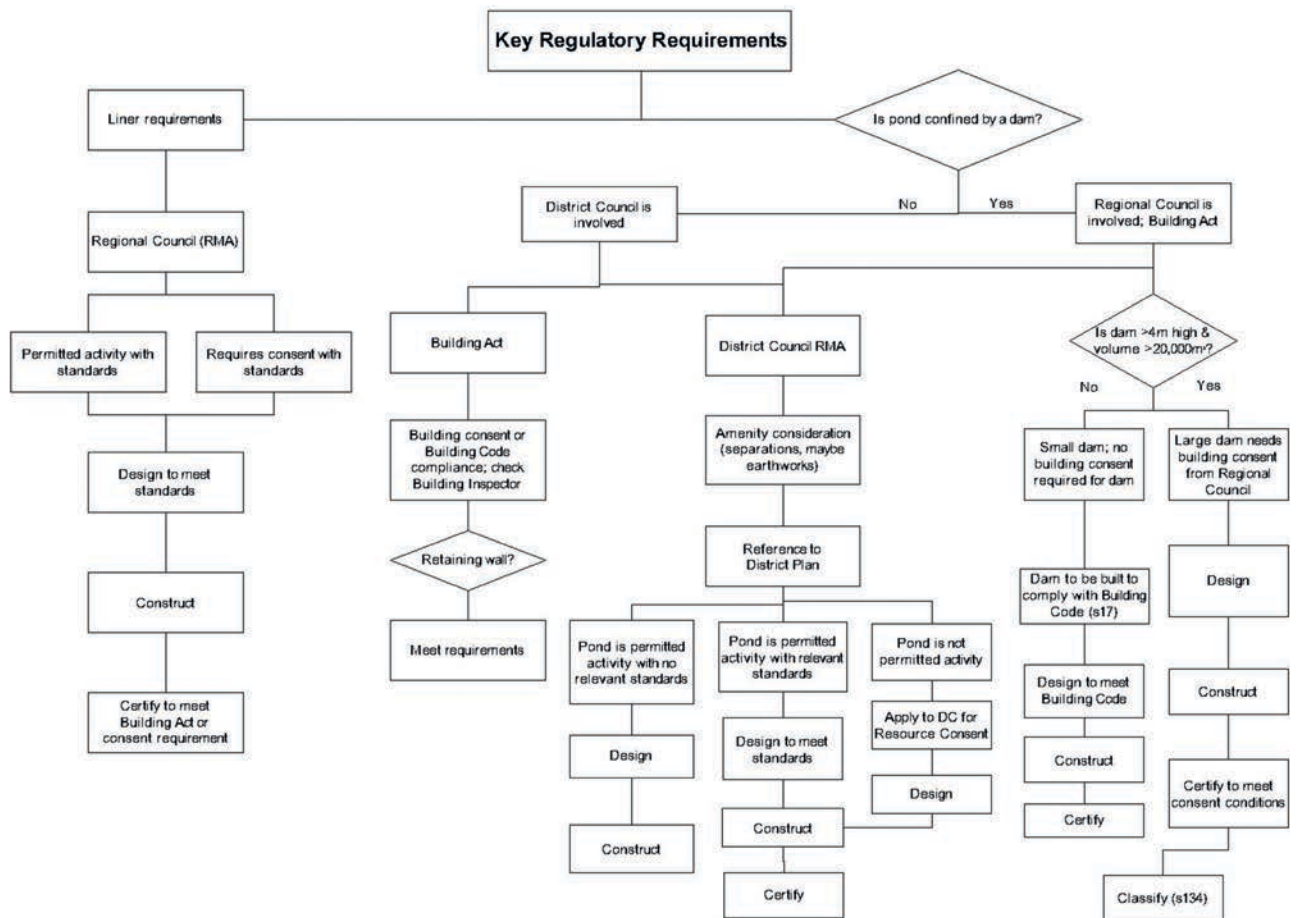

Figure 3.2: Regulatory Decision Flow Diagram



4. SITE INVESTIGATIONS

4.1 INVESTIGATION PURPOSE: AN OVERVIEW

Site investigations provide information about the possibility for a sound structure that meets Territorial Authority and Regional Council rules to be built, given the site conditions. Investigations and reports may need to be carried out by Chartered Professional Engineers (Geotechnical) or engineering geologists where land conditions are complex or soils are not straightforward. The farm owner/client, in discussion with the designer and regional or district consenting authority, should determine any local or regional policy or conditions that require soil investigations/reports to be carried out by a geoprofessional.

4.1.1 New ponds

For new FDE ponds, the proposed site should be thoroughly investigated before design and construction begins. Generally, an FDE pond should be in an area with low permeability soils to reduce the risk of seepage loss.

Soil profile samples should be obtained to provide information on the material properties. These should be taken from the surface down to beyond the base of the proposed pond. The prevailing groundwater regime is also critically important.

4.1.2 Existing ponds

Assessing the potential for an existing FDE pond to leak is difficult. However, it may be possible to see if it is leaking from visual observations and by measuring fluid levels over time, while allowing for evaporation. Visual assessments to determine obvious high-seepage zones (for example, through embankment or conduits) are good starting points. It would also be prudent to establish whether the existing liner (if present) has been damaged.

These assessments could be followed by verifying the soil profile and characteristics around representative portions outside the pond using the techniques described below. Associated permeability testing may also be necessary to confirm the seepage rate of the soil profile, to confirm whether unacceptable seepage is an issue.

If there is any doubt about a pond leaking and no obvious cause is located, then environmental sampling and investigation may be required to pinpoint the source and impact of any contamination.

4.2 SOIL PROPERTIES

Site investigations must be detailed enough to identify the variations in soil types present at the site.

The New Zealand Geotechnical Society (NZGS) has a guideline for the field classification and description of soils and rock (refer to References section).

Early in the investigation the designer needs to consider whether a clay or synthetically lined pond is most likely required. This will ensure the investigation is more precisely conducted to collect relevant information.

Clays and silty clays are the most appropriate natural materials for pond construction. In some cases, where sand, gravels, pumice, and other highly permeable soils prevail, the only solution will be a synthetic lining material or a CCL using suitable imported/borrowed materials. A synthetic lining should be considered at sites where soils are unlikely to be able to meet the liner permeability requirement specified by the Regional Council.

4.3 SITING A NEW POND

It is appropriate to investigate where a pond will be sited and to avoid installing design elements that allow for the pond's proximity to sensitive features. These features can include surface water bodies, artificial watercourses, installed subsurface drains, groundwater level, bores, registered drinking-water supplies, coastal marine areas, trees, stop banks, residential dwellings, places of assembly, urban areas, property boundaries, milking areas, and sites of cultural significance. It should be noted that prevailing winds can carry odour some distance.

Unknown sites of cultural significance are unlikely to be identified before works begin. However, if discovered during construction, works should cease and the site should be reported immediately to the NZHPT and local iwi representatives.

Pond placement and orientation should also consider potential slope instability, inundation from flooding, diversion of flood flows, and stormwater in-flows. In areas subject to actual or potential inundation, the pond base should be at least 1 m above the highest known flood level if possible. If not, then specific engineering design should be undertaken. It is also preferable that long ponds be orientated along the flood plain rather than across it, and perpendicular to the prevailing wind to reduce the effect on wave action and potential spillage if the pond level is high.

When assessing a site for its suitability for pond construction and the availability of materials the following factors should be considered:

- The type of soil material present at the site
- The soil profile to at least 1 m below the finished base depth. How the soil texture may vary down the profile and if there are inherent potential problems due to layering of the materials present. The materials available for bank construction, and/or for lining the inside of the pond
- The potential for variation in the soil profile across the pond site
- Proximity to natural ground slopes acting as an outer dam embankment wall
- Whether the base of the pond is well above the maximum predicted level of groundwater; the slope stability and landforms present.

Other recommendations:

- Locate the pond clear of any watercourses, including secondary flow paths; also, stream/gully channels
- Check the ability to gravity feed the FDE to the pond from the dairy shed rather than needing to pump
- Place the site as close as possible to a suitable power source to minimise cost of getting power to the pond if required.

Ponds should be located well clear of trees or shelter belts (about 20 m or two thirds of the tree height) to:

- Avoid damage to synthetic liners from wind-thrown branches
- Minimise debris which would otherwise collect and block pump screens
- Avoid ingress of tree roots into the pond walls.

Figure 4.1 provides a graphic showing some site consideration factors.

Another important consideration in some regions is the time of year construction is planned to take place. While an earthen embankment pond may be very difficult to construct in winter in some regions, alternative pond systems (for example, precast concrete panelled tanks) can be constructed in winter.

The Ministry of Primary Industries requires dairy to specify certain requirements, such as their effluent storage facilities' separation distance from their milking sheds. Designers should ask pond owners to confirm the industry standards that may affect their containment facilities' design, placement, and construction.

Figure 4.1: Site Considerations (allowable distances vary between Regional Councils)

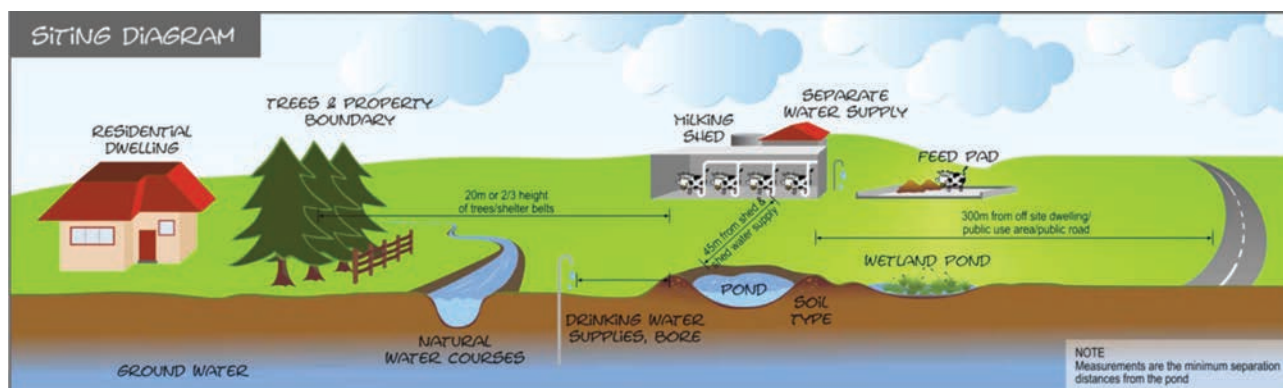

4.4 FIELD INVESTIGATION STEPS

Designers need to arrange for field investigations and prepare site investigation reports. Copies of these reports may be required by Regional Councils to be included with pond consent applications.

The field investigation steps are described below.

Step 1: Assess and record the site's overall terrain. Need to note: slope stability, surface water, and vegetation type. The site should be devoid of trees to avoid the presence of tree roots near the pond.

Step 2: Undertake the investigation to at least 1 m below the finished depth of the pond to determine the type of soil materials present. This will require using a hydraulic excavator to dig the investigation test pits across the proposed site. Adhere to WorkSafe New Zealand requirements for working in and near trenches.

Step 3: Log and photograph the soil materials to determine the type of soil present, its physical properties, and overall profile. Record any variations to the natural soils materials such as imported fill containing wood, plastics, or metals as well as any voids created by tree roots or water erosion, as these may render the site unsuitable. Give special attention to any collapsing of the test pit sides and its mechanism for failure, as this may be an indicator of substandard performance for the material type present.

Step 4: Closely assess the soil texture and materials to establish whether a synthetic liner is needed to be fitted inside of the excavated pond. If the *in situ* soil itself is intended to be used as a clay liner, then this must be substantiated by testing as outlined in Part 2 (Clay Liners). (Note that while a soil may have suitable properties to comply with a "sealed pond's" permeability requirements, the soil structure and texture ultimately govern its permeability by its preferential flow paths.)

Step 5: Where a clay liner is considered an option samples of the borrowed material need to be taken for laboratory testing. It is important none of the samples contain any organic material, so topsoil must be excluded. Bulk samples should be placed in a labelled, air-tight plastic bag. Laboratory tests for clay liners are described in Part 2, section 3.

Step 6: The soil investigation test holes are necessary to assess the level of the water table and seasonal fluctuations. These fluctuations can be significant and must be determined if the pond's floor level is to be set at a safe height. Some sites may have a temporary perched water table in winter due to impervious subsoil which overlies the main water table. This is typically indicated by soil discolouration; red-brown indicates oxidised free-draining conditions while mottled grey indicates lack of internal drainage. Typically, dark grey or blue-tinged soils indicate permanently wet strata.

4.4.1 Groundwater

Test holes in late winter will often show the highest water table's location. However, test holes at other times of the year may be required to obtain reliable data. To monitor the groundwater level, a piezometer can be installed. The groundwater level can then be measured by inserted a measuring device and recording the depth of the water below the ground surface.

Local knowledge, if available, should also be considered. In addition, the local Regional Council may have information on groundwater levels throughout the region, which will be available upon request.

Where there is subsoil, there will usually be indications of fluctuations in the water table in the soil profile. For profiles without a subsoil (that is, gravels), the water table fluctuations may be more difficult to establish. The accumulation of iron and manganese, for example, can show the range in water table height. They may also show historic high water table levels which are no longer relevant.

Agricultural land that has typically been artificially drained with tiles or mole ploughed, and the presence (or otherwise) of drainage, may also influence water table height and allowance must be made for this. Pond construction must also allow for detecting and removing or replacing tile drains that may be present under or near the pond structure.

Groundwater monitoring is required to ensure the pond's proposed base is well above the maximum predicted groundwater level. It is considered inappropriate to construct ponds below the groundwater profile. If this must occur, then specific design from a geotechnical professional must be sought.

Key Points

- Consider if a Chartered Professional Engineer (Geotechnical) or engineering geologist is required to carry out the site investigation
- Consider distances from shed, waterways, houses, trees, boundaries, and power source when deciding where to locate ponds
- Site locations need to factor in milk company requirements
- Site investigations must identify all soil types present
- If using compacted clay liners, it is essential to get the clay tested through a professional engineering laboratory
- There is a range of liners and manufactured products available
- Know where the water table and drains are located



HDPE synthetic liner being installed

5. FDE SYSTEM ELEMENTS

5.1 INTRODUCTION

Before any design decisions are made about the pond materials, configuration, and construction, a clear understanding needs to be reached with the client about:

- How the pond fits into the overall FDE system?
- What type of pond system they require?

There are several approaches to managing FDE and each requires quite different pond designs.

5.2 TYPES OF PONDS

Some current pond styles include:

- A single-pond system, collecting raw effluent. This can provide for moderate settling of the solids (forming a sludge unless stirred) prior to the fluid component being discharged and pumped to a land application area. In many cases the single pond is used for bulk deferred storage with no requirement for settling; it may have a stirrer installed to mobilise the sludge for irrigation to land
- A two-pond system involving a typically anaerobic primary pond used for settling solids flowing into a secondary pond which can be aerated to further treat the effluent before it is discharged, or being further clarified (through solids settling or removal), before being discharged
- Multi-stage ponds similar to wastewater treatment facilities with various settling, clarification, aeration, and disinfection processes prior to the effluent being discharged (typically) to a waterway or land
- One- to two-day capacity sumps that collect the raw effluent, which is then discharged via a high-rate travelling irrigator to pasture. These are not considered suitable in some regions to manage effluent and maintain compliance throughout the year.

Current good-management practice is for the construction of deferred irrigation storage ponds, so when the soil moisture conditions are suitable the effluent can be discharged to land. Otherwise it is stored.

5.3 EFFLUENT TREATMENT DESIGN

5.3.1 Anaerobic and aerobic ponds

Commonplace treatment in the past was a twin anaerobic/aerobic pond system which usually discharged to water. However, increasing regulation by most RAs has seen these systems reduce in number across New Zealand.

Traditionally these ponds have been intended to function as treatment ponds. They maintain a constant level, with varying seasonal inflow and rainfall, with a related discharge from the pond. Pumping out and desludging the ponds would be an infrequent occurrence, and the pond would rapidly return to a normal operating level regardless of whether the intended physical and biological processes were present.

Where new anaerobic ponds are designed, they should have a normal operating range of >1.5–2.0 m with a total depth of at least 3 m, although four to 5 m is ideal. Shallower treatment ponds (unless mechanically aerated) will be “facultative” with a layer of anaerobic activity on the base and a thin layer of aerobic water on top.

5.3.2 Effluent ponds as storage

Current industry good practice is for the pond to act as a reservoir, providing buffer storage of effluent for periods (possibly up to six months) when ground conditions do not allow land irrigation. In this mode, the pond is normally at a low level (possibly empty for long periods through the summer) then filled gradually during wet weather, but may be drawn down quite rapidly when irrigation is resumed. Earthworks and lining systems for this type of pond operation need to recognise this fluctuating water-level pattern.

5.4 SOLIDS MANAGEMENT

5.4.1 Solids removal

Traditional FDE irrigation involved pumping directly from the yard or transfer sump (10–30 m³) to pasture. The sump may have had one or more stirrers to agitate the sump's entire contents. The resultant slurry was then applied direct to land via a high-rate travelling irrigator.

Newer FDE systems incorporate a stone trap prior to flow to a large transfer sump (or tank) of 20–140 m³ in size. On days where irrigation is allowed, “raw” FDE is pumped directly to irrigation without separation. During days where irrigation is not permitted, effluent can either be passed through a solids separation process (or not) and stored until irrigation is again permitted. The FDE is then either pumped directly from the pond to irrigate the pasture or returned to the sump for irrigation from there.

If solids are removed before the FDE reaches the storage holding pond, problems with pond solids' management are reduced or eliminated. Solids removal is commonly achieved by either mechanical or non-mechanical methods.

5.4.2 Mechanical separation

Mechanical separators are typically designed to remove solids down to less than one millimetre. The resulting liquid contains only fine suspended organic material and silts/clays, plus all the dissolved nutrient value (mainly Nitrogen and Potassium). Phosphorus tends to be in the solid fraction but may also form soluble salts and fine particulates in the effluent.

It is important to be clear about what the farm owner/client plans to feed through the mechanical separator and how this may affect the separator's performance. In this context, it is also important to consider the separator's capacity to ensure it will adequately meet the farm owner/client's current and future needs.

5.4.3 Non-mechanical separation

Non-mechanical separation methods include “weeping walls”, settling ponds, slope screens, and rotating drum systems.

Recent weeping-wall system developments have improved wall design practice. Good wall design now includes the following common elements:

- Tapered timber or suitably robust plastic or concrete battens with appropriate maximum opening between battens can be used to construct the wall
- International guidance has resulted in wall porosities of 15 to 30 per cent to prevent blockages
- The wall's specific engineering design ensures it remains structurally sound when the pond is full
- The wall's large surface area ensures low flow rates and reduces the potential for solids passing through it
- The wall's height is no greater than 2 m.

Where gravity systems are used, the bottom of the wall is below the storage pond's maximum fill level. There are some other systems in development which are likely to provide other options to these in the future.

5.5 EFFLUENT IRRIGATION

The preferred effluent irrigation method will depend on effluent volume, treatment levels, the terrain to which the FDE is applied, budgetary constraints, soil properties, and nutrient constraints.

It is not intended that this document go into detail on effluent irrigation, this being covered in the *DairyNZ FDE Design Code of Practice* and other publications. However, the following information on effluent irrigation is provided to give pond designers general awareness on irrigation delivery methods available.

Table 5.1: Irrigation Delivery Methods (To Pasture)

Centre pivot irrigators	A large-area irrigator with prior solids treatment is required. It requires separate piping for effluent and water irrigation, and is most suited to large operations with flat land. The speeds can be altered to apply high and low application rates, and large volumes (>100 m ³ /hr) can be shifted.
Travelling irrigators	These are large self-propelled wheeled sprinklers with one main drag line. Little treatment is required, as travelling irrigators can generally handle solids well. They typically apply high depth rates. Newer irrigators have been designed to provide lower-depth applications while still having high rates of irrigation. Discharge volumes from 10–100 m ³ /hr are common.
Pods	<p>These are small static sprinklers that require regular moving. There are two main types: “K-line”, a 4 mm nozzled sprinkler that requires solids removal and many sprinkler heads in a set (20–100+ depending on farm size)</p> <p>Larger sprinkler heads with 9 to 15 mm nozzles typically in sets of four to five pods perform better with solids removal but are not essential to operation. They are suitable for all terrain. Low-rate application typically <4 mm/hr. Pods have the benefit of pulse application rates, with sets of pods timed for short periods to allow very low average application rates of <1 mm/hr while still achieving volumes discharge requirements.</p>
Guns	These large sprinkler heads are like raw pods on sprinkler stands and are moved from paddock to paddock. They are connected to preinstalled hydrants or pipework in paddocks. They require frequent moving and can cope with well-treated or raw effluent but need specific setup for each. The guns tend to be forgotten if not electronically monitored, causing over-application. Multiple guns can be connected to a manifold to allow low/pulse application.

Note: If it is intended to connect effluent pipelines to systems primarily intended for water irrigation (for example, centre pivots), then appropriate risk assessment for back-flow prevention to prevent clean water supplies being contaminated should be carried out. Ideally, separate pipework should be installed to eliminate the risk.

The actual irrigation method will have an impact on pond design, with variations depending on the effluent’s treatment and function. In all cases, there will need to be a formed effluent abstraction point, and all-weather access for an excavator or maintenance vehicles to service or replace pumps etc.

Several different equipment options for FDE intake from a pond can be used and will impact on the appropriate pond geometry design.

Table 5.2: Irrigation Intake Options (From Pond)

Floating pontoon	The floating pontoon has a pump intake suspended below it with other ancillary equipment (for example, a stirrer) attached. It requires a minimum water level to prevent it running dry. This will affect useable pond sizing, unless a specific pump sump is built in. Access for the pump may be a difficulty. Recent guidance from WorkSafe New Zealand should be consulted on the appropriate access provisions.
Jetty or structure	The jetty or structure is set into the pond from which the pump and ancillaries can be secured. Health and Safety issues including barriers need consideration. Building Consents will generally be required.
Self-priming pump	The self-priming pump has an intake line into the pond and screen is typically a centrifugal pump requiring low-solids effluent for best performance.
Positive displacement pump	A positive displacement pump which can process higher solids content, such as progressive cavity pumps, can be set up with an intake pipe into the pond with suction screen. Progressive cavity pumps can also be either vertical pontoon mounted or pond crest mounted.
Pump sump	A pump sump in the base of the pond with the base sloping down into it will allow maximum draw-down of the pond while allowing pump intakes to remain submerged. It also facilitates easier access for maintenance with flushing or scraping of sludge to the pump-out point.

*Sludge bed with double weeping wall and PVC battens*

5.6 POND SIZING

5.6.1 Deferred irrigation storage

Where a pond is being designed as a deferred irrigation storage pond, the size needs to be derived from a water balance approach to cover the expected “wet year” period. This is when irrigation may not be allowed due to soil-saturation levels. Guidance should be sought from the Regional Council or best-practice guides for rainfall return periods for calculating maximum annual storage-pond volume.

Size of storage is determined by considering various factors, including:

- How the farm owner/client wishes to manage his FDE
- Number of days FDE storage is required (by Regional Council or design standards, whichever is the greater)
- Normal daily FDE production volume – some Regional Councils require a per cow volume
- Rainfall
- Soil saturation levels – prevalence of weather conditions and/or soil type where effluent applied would either excessively pond on the soil surface or runoff to surface water, both of which are unlikely to be allowed under Resource Consent conditions
- Maximum nutrient loading, as required by Resource Consent, or best practice, or catchment regulations, while allowing for nutrient concentration in effluent
- Proposed irrigation method and pumping rate. Low-application irrigation provides a wider window of opportunity to irrigate soils near field capacity, while systems with a high pumping capacity allow more effluent to be irrigated in a short time and therefore the pond volume can be lowered quicker. The daily irrigation volume must be at least double the daily input or the pond is unlikely to be emptied
- Expected solids accumulation in the pond
- Allowance for the minimum level to which the pump can draw down to (for example, if on a pontoon, it may be best to provide a sump in the pond over which to locate the pump)
- Minimum freeboard of 0.5 m but may need to be greater depending on pond size and prevailing wind conditions
- Breakdowns and maintenance contingency allowance
- Allowance for future stocking rate (for example, increased herd size, or increased shed utilisation or addition of a feed, standoff, or silage pad).

Water balance model is best calculated by using the Dairy Effluent Storage Calculator (DESC) developed by Massey University with support from Horizons Regional Council. It calculates the required stored volume based on certain factors including rainfall from the previous 30-year period and soil types. However, the following should be noted:

- Local rainfall variability should be considered in sizing based on the pond calculator, as coverage of rain-gauge sites in the calculator is limited in some regions, although more will be added with time
- The Regional Council will set the rainfall return period, which may be more frequent than one in 30 years
- There is currently some variation in the amount of storage that different Regional Councils require. It is recommended that sizing be based upon a rational assessment of water balance and irrigation application rather than a council minimum storage requirement where the latter gives a lesser volume. This will ensure the installation is future-proofed
- The DESC determines pond working storage volume and does not currently allow for freeboard or sludge accumulation volume, but does allow for a specific number of days of “emergency storage” to be added.

5.6.2 Retention time

Where ponds are being designed as a treatment component with normal constant level and daily liquid removal, then sizing will be based on retention time. Additional ponds or capacity are included separately for the deferred irrigation requirement.

For solids removal, allowance needs to be provided for sludge accumulation. Around 1.5–7 per cent of the shed effluent may be solids (a highly variable figure depending upon water use, feed, and season). Feed pads will be different again, as there tends to be a larger solids component due to feed wastage (15–45 per cent).

Allowance should also be made for the time interval between solids removal with timing of this in line with the farm management and seasonal work load. Above the sludge storage allowance will be the liquid volume required to achieve settling. In effect, the treatment pond is being designed as a rudimentary clarifier and normal surface-loading rate considerations would apply.

For oxidation or aerated ponds the sizing will be provided by the treatment process designer and is not within the scope of this Practice Note.

5.6.3 Effluent production rates

Per-cow effluent production figures should be used with caution. They will vary widely from site to site depending on milking times, shed type, stock handling, feed, season, and wash-down methods. While a “typical figure” of 50–70 litres/cow/day is often quoted for dairy shed effluent, poorly set-up sheds may use more than 90 litres/cow/day.

To confirm the design FDE volumes, for example, from the DESC, are consistent with the actual volumes it is sensible to measure the actual production (in dry weather). This may be possible by measuring the input water to the shed over milking (watch for milk chiller water as this should not be feeding into the effluent), plus an allowance of about 10 per cent for urine and faeces. Alternatively, measure the effluent being pumped away. Allowance should be made for shed upgrades that change the herd size or water management regime of the shed.

For a new farm/conversion, typical figures will need to be relied on. It is suggested that designers seek input from the milking plant installer, especially when green water reuse systems are to be installed. IPENZ promotes good-practice guidelines for water conservation and use.

5.7 POND GEOMETRIC DESIGN

5.7.1 Geometry

While there are no specific requirements for storage geometry, the pond’s operation and use will govern its shape. For treatment and settling ponds in general, a long pond with a set width will be better as it will be easier to clean and provides a longer path for the solids to settle out. A 2:1 length to width ratio is often used. Consideration should also be given to access for solids removal. The width of the pond will be determined by what equipment will be used to carry out solids removal. Likewise, the depth is constrained by desludging equipment, unless specific ramp access is incorporated into the design.

Where a pond containing unprocessed FDE is to be stirred prior to pumping, a round pond would be preferable. Contacting the stirrer supplier is recommended to ensure that the pond can be effectively stirred given the proposed pond size.

A long and narrow deferred storage pond should be orientated to avoid the longest dimension being in the direction of the prevailing wind as wave and wind action may increase risk of wave action damage or overtopping/splash. It is also preferable to have rounded interior corners rather than sharp changes in direction which have a higher scouring risk.

DairyNZ has developed a spreadsheet based tool to assist in calculating the working volumes and true dimensions of a new or existing storage pond or tank. It can be used for square, rectangular or circular facilities. The calculator should be used in combination with the storage volumes generated from the Dairy Effluent Storage Calculator, or for calculating the working volume of existing ponds and tanks. A link to it is contained in the References section under DairyNZ.

5.7.2 Batter slopes

Both inside and outside fill and cut batters should be no steeper than 2:1 horizontal (H) to vertical (V). Batters steeper than this will need a specific geotechnical assessment for suitability. Where the local soil conditions are known to be sensitive, then flatter batters should be utilised.

Where clay liners are used, the type of construction plant available will determine batter slopes. On slopes steeper than 3:1 (H to V) it will be difficult to achieve adequate compaction of the clay liner to the required specification by traversing the slope. Standard construction methodology as outlined in NZS 4431 is a prudent method of placement. One way around this is to construct in horizontal lifts and then trim back to the desired slope.

Synthetic liners can be laid on steeper slopes if a specific soil-slope stability assessment is conducted. Careful consideration and assessment of the steeper batter under both drained and undrained conditions will need to be conducted to ensure the steeper batter is not at risk of slumping or eroding behind the liner. If moisture or water could enter and create undrained conditions, then a drainage layer on the batters and base of the pond would be required. Ponds should not be installed below the highest expected groundwater profile.

Batters must be stable under applied loads from vehicles, for example, tractors or trucks carrying out pump servicing or desludging operations.

5.7.3 Spillways, pipes, and filter collars

In addition to stormwater diversion, ponds may require a specifically designed emergency spillway for protection from severe storms to avoid overtopping. Means to avoid or mitigate overtopping should also be considered. Spillway design has not been included in this Practice Note and designers should refer to references such as KD Nelson's *Design and Construction of Small Earth Dams* (refer to the References section under Pond Design and Construction).

Typically, the weakest point in a pond is where pipes penetrate embankments, so pipes through embankments that are below the highest pond water level should be avoided. These pipes should have filter collars to prevent piping failures. Traditional seepage collars no longer represent best practice. If a pipe penetrates a liner, then a liner sleeve or boot should be installed around the penetration to ensure the penetration is watertight. Pipe penetrations in CCL ponds will require a long leakage path to provide water tightness, which can be achieved by using a puddle flange.

Where FDE discharges from an open pipe onto a liner this may cause abrasion, and scouring of the liner surface over time. The effects of this can be reduced using concrete channels, an additional layer of synthetic lining, and rubber mats.

Where a suction pipe is used, this should be placed through the embankment berm at a height that assists pump priming. An HDPE pipe should be used and be fitted with HDPE collars.

Pond designers should consider using the services of a specialist engineer to assist with detailing of these important pond design aspects.



GCL liner to FDE pond.

5.8 SOLIDS MANAGEMENT DESIGN

5.8.1 Clean-out design

At the design stage, consideration needs to be given to how the pond will be accessed for cleaning or for servicing of pumping and stirring equipment. This will likely require provision of a section of an all-weather track and a hardstand where service vehicles (for example, a truck with hydraulic arm) can be parked. A suitable grade should be provided on the access track.

Increasingly, farmers are choosing to separate solids out from FDE prior to pond storage to simplify the management of effluent, tighten management of nutrient application, and reduce potential Regional Council effluent non-compliance.

For synthetic-lined ponds where solids can accumulate, they may be cleaned out using a floating pump and stirrer, or a shore-mounted suction pump with an intake on the base, or a slurry tanker. They should not be cleaned out with hydraulic excavators or loaders etc., unless appropriate protection layers have been provided. Consultation with the supplier of the synthetic liner is recommended.

A CCL pond that is cleaned out regularly will need to be relined periodically as there will have been loss in the thickness of the clay liner during the cleaning operation.

5.8.2 Liner protection for mechanical cleanout

For a synthetically lined pond to be safely cleaned out by excavators and other equipment, the pond must be specifically designed and constructed to provide liner protection from the action of the equipment intended to be used. The base and side walls must be robust, and reinforced concrete would generally be used for this purpose. This concrete will need to be specifically designed to prevent excessive cracking during excavator loading. It will also need to have its buoyancy checked, as fluid will get between the liner and the concrete if a bathtub-type concrete base has been constructed.

Where a pond is proposed to be agitated as part of the solids removal operation, then a protected area should be placed on the pond floor and batter to provide a “stirrer point”. This could be a concrete slab extending some 3 m by 3 m over the floor. Discussion with the irrigation supplier as to their requirements is advised. Depending on the size of the pond, it may require stirring at several locations to fully agitate sludge layers, so more than one stirrer location could be needed. Full agitation may be very difficult to achieve on larger ponds.

Discussion is advised with the liner supplier to establish any specific requirements they have regarding concrete or structures on the liner. Typically, a very robust protection geotextile would be placed on top of the synthetic liner if concrete is then to be placed.

Clay liners are particularly vulnerable to damage from stirring and will need to be protected. One solution is to use cast *in situ* concrete slabs on the base of the pond and graded rock armouring with a geotextile separating layer on the batters. The rock armouring will need to be specifically designed for the current and vortex forces that will occur in the pond. It is not recommended that clay ponds be stirred without armouring.

5.8.3 Sludge beds, bunkers, and draining pads

If solids are to be stored on site then these will need to be held on a confined area designed and constructed to provide at least the same permeability criteria as the pond liner, which is 1×10^{-9} m/s, or as required in the Resource Consent. Lining options for sludge beds/bunkers and draining pads include:

- A concrete slab floor with a nib wall or bunker wall. Practically and serviceability wise, concrete gives a good long-term result
- A GCL under a confining layer of cohesive material
- A premium-grade synthetic liner in conjunction with a geotextile underliner. A textured HDPE liner with a cohesive cover layer is another option.

The design of these structures needs to be such that effective draining and drying can occur. Drainage from the base needs to be either contained or directed back into the effluent containment system.

5.9 LINERS

5.9.1 Liner options

Liners can be formed from compacted clay; or specially manufactured geomembrane materials such as polyethylene, polypropylene, synthetic rubber, geosynthetic clay; or concrete.

It is imperative that the type of liner selected is appropriate to the intended purpose and that due diligence is observed during preparation, installation, and subsequent use. No matter what type of lining material is used, defects from inappropriate installation or use are likely to result in consent non-compliances, costs of remedial work, and wasted capital invested in a structure that fails to control environmental liabilities.

Table 5.3: Pond lining options

Pond Lining options	Refer
<i>In situ</i> clay	Part 2
Compacted clay	Part 2
Geomembranes (synthetic liners)	Part 3
Concrete	Part 1, Section 5.9.2

5.9.2 Concrete liners

Sprayed concrete using compressed air, also referred to as Shotcrete, can be placed as a wet or dry concrete mix to form a liner.

To avoid slumping, this concrete mix is likely to be a special mix of chemical additives, silica sand, fly ash or aggregate, and cement. Synthetic fibres may also be used as an alternative to the use of a wire mesh or metal reinforcing bars. The addition of such fibres will provide improved compressive strength, flexural capacity, and impermeability.

A geotextile or synthetic liner under the liner is required to minimise soil contamination and to dissipate groundwater and sub-surface gases.

5.10 POND PERFORMANCE CONSIDERATIONS

5.10.1 Drainage control and leak detection systems

Piping failure (erosion along lines of weakness) in soils underlying ponds should not be an issue with a properly constructed and maintained FDE pond where leakage is very low. If foundation soils are dispersive, or otherwise prone to piping and formation of sub-soil cavities (tomos), specific underdrainage provision may be prudent.

An FDE pond would not normally be designed with secondary lining and leak detection systems; however, RCs are increasingly encouraging these features in pond design. Foundation soils will generally be orders of magnitude more permeable than the pond liner. Small leakages will dissipate to the soil. If underlying soils are slowly permeable (for example, $<1 \times 10^{-6}$ m/s), then an underdrainage system (gravel layer or strip drain) could be incorporated.

Whilst it is recommended that the highest water table level for a site be below the base level of the pond, this is not always achievable. In this situation, liner and pressure release design is particularly important.

Water drainage and water table management can be via trenches. Generally, these are either permeable material wrapped with a geotextile or perforated drainage pipe wrapped with a geotextile to avoid finer particles entering. Drains should be placed approximately 5 m apart, in addition to being positioned around the foot of the base perimeter. For smaller ponds a ring drain placed at the foot of the batter slope should be suffice. To further aid drainage, allow for 100 mm of drainage metal over the drainage system.

The water drainage network should culminate in an inspection point; this allows the collected liquid to be tested and liner leakage to be ruled out.

A Leak Detection System (LDS) installed at the time of pond construction will provide a very convenient means of providing ongoing leakage detection. These systems consist of a water drainage network (aggregate or piping with impermeable base layer) underneath any clay or synthetic liner, which drain to an inspection well. Liquid in the well can be easily inspected, collected, and, if necessary, tested to determine the source; groundwater will tend to be low in nutrients, solids, and bacteria, whereas FDE will be high in all three.

The well itself should be 400 mm or greater in diameter, for example, formed from a length of culvert pipe and able to be easily sampled from (using a suction pump or grab system). Further, the inspection well should be weathertight, stock-proof, and sealed around the ground surface.

A pond drop test may provide a more conclusive measure of water-tightness but only if there is a major leak. However, an effective LDS will provide a much earlier indication of leakage.

An alternative LDS technique that is relatively new to New Zealand is electric field testing. Water as a conductive medium is applied to a membrane surface, and a tear or leak in the membrane creates a fault that can be detected.

5.10.2 Gas drainage

Drainage of gas from beneath the liner is an important consideration where synthetic membrane liners are used. If the pond has a large flat area and gas is unable to escape to the surface, then the liner will float in large bubbles (also known as humpback whales or hippos). Gas could be the result of decomposition of organic matter in the soil (for example, peat, residue from an old unlined pond, unknown leaks), air trapped by a fluctuating water table, or decomposing effluent (from a previous pond).

Gas drainage could be provided by an aggregate layer beneath the liner (in which case, check for compatibility between the liner membrane and the stone size, or by synthetic drainage products, with a minimum fall of two per cent to allow for positive gas movement. Gas should then be appropriately vented to the surface. Note some saturated gases will drain downhill and may need to be dealt with separately to volatile gases.

The geometry of the pond base is important to ensure gas drainage – slope at one per cent upward from the centre. A narrow base width of with shallow batters could be a better configuration than a wide base with steeper batters if gas is anticipated.

Geotextile is often recommended for both clay and synthetic liners, sometimes above and below, but in particularly underneath of the liner. The purpose of a geotextile is to provide separation of fines or to protect the liner from puncturing. Some geotextiles available provide both fines separation and gas drainage.

5.10.3 Health and safety requirements

Steep lined slopes, whether slick clay or synthetic membrane, are a hazard for farm workers (and stock). All ponds should include at least one ladder or alternative escape means in the event of a fall into a pond. Larger ponds will require several such escape routes.

Similarly, all ponds should be fenced off with a netting fence to prevent stock (and children) from straying and falling into the pond.

Key Points

- **Pond storage volume: allow for maximum herd size, any silage pit and feed pad runoff, rainfall, yard wash-down, future-proofing**
- **Prepare detailed construction documents: drawings, specification, schedule of quantities, cost estimate**
- **Orientate pond to reduce potential adverse effects of flooding and wave action**
- **Include drainage and gas venting systems in pond design**
- **Where a pond requires stirring, ensure pump sufficient to adequately stir the volume**
- **Design for Safety covering the whole life of the FDE pond system**
- **Seek and consider advice from liner/containment specialists.**

6. DESIGN AND CONSTRUCTION

6.1 INTRODUCTION

Every FDE pond is different and there will be variations in the design and construction of each. This section sets out some important items that should be considered by designers, farm owners/clients, contractors, and suppliers:

- Meeting the farm owner/client's needs
- Preparing a design
- Meeting consent and regulatory requirements
- Monitoring the construction
- Ensuring quality-assurance requirements are in place.

6.2 DRAWINGS AND SPECIFICATIONS

For a contractor to construct a pond that achieves the design criteria, detailed drawings and specifications are required.

Drawings need to provide sufficient detail so that the contractor can clearly understand the designer's intentions and requirements.

Designers and contractors should make themselves familiar with the requirements of NZS 4431:1989 (Earth Fill for Residential Development), particularly sections 6-11.

6.3 CONSTRUCTION MONITORING

The level of construction monitoring needs to be determined by the designer prior to construction in consultation with the farm owner/client, and will depend on the complexity of the project. Guidance on Construction Monitoring can be found on the IPENZ website.

At the works' commencement, the project manager should ensure that the contractor has a copy of the Resource Consent issued by the Regional Council which permits the pond to be constructed (if that is required), and that the contractor and person carrying out construction monitoring are fully aware of any Resource Consent conditions. During construction, the person carrying out construction monitoring will need to confirm that all specification requirements are being complied with.

During excavation, the person engaged to carry out construction monitoring needs to be aware of any material substantially different from that revealed in the pond site investigation and soil analysis. Re-assessment of the material may be required if variations impact the consented/agreed design. An adjustment may require formal amendment or variation of the Building Consent under the Building Act (and possibly the Resource Consent under the RMA) prior to undertaking construction.

The person carrying out construction monitoring must satisfy themselves that sufficient compaction to the fill material has been applied. This may be determined by a combination of laboratory and field tests, or compaction trials, together with experience in the plant and materials being used.

6.4 EFFECTS OF WORKS ON OTHERS

The contractor will need to carefully consider the site conditions and timing of the contract with respect to the potential for runoff, dust, and noise generation from the works.

The contractor should arrange and control the work so that the construction of the pond will not cause contamination of waterways or a dust nuisance to any nearby properties. A water cart should be on site to dampen down any area causing a dust nuisance.

Works may have to be arranged to minimise inconvenience to the farmer in their dairy farm operation and work around cow movements and milking times.

6.5 UNDERGROUND SERVICES

Utility providers and the farm owner/manager will need to be approached as to the location, line, and level of underground services before commencing operations in an area, and take steps necessary to prevent damage to, or accidents arising from, interference with any pipes, cables, ducts, and underground structures.

Permanent relocation of water troughs, water pipes, and irrigation infrastructure may be necessary and relocation arrangements for these agreed with the farmer.

6.6 DRAINAGE CONTROL

Measures should be taken early in the work to maintain the natural water drainage facilities and avoid the introduction of water into the earthworks. Adequate provision should also be made for the control of waterborne soils/silts and the contractor may need to install temporary silt fences to protect waterways from contamination.

In addition, temporary drainage works may be required during construction to control groundwater and surface water and safeguard the integrity of the works. It is important that the earthworks be carried out in such a manner that surfaces have a sufficient fall to shed water and prevent localised ponding.

Where an existing subsoil drainage or drainage path is encountered, or will be intercepted, subsoil drains need to be constructed to direct flows away from the constructed fills and embankments. These subsoil drains need to have sufficient fall to prevent blockages and be self-cleaning.

6.7 CONSTRUCTION EQUIPMENT

The type of excavating equipment for construction will depend on scale, availability, the design, climate, and physical conditions at the site. Most types of equipment can be used during dry periods. The most common types of equipment used are motorscrapers, bulldozers, and hydraulic excavators.

Construction machinery needs adequate room to work and the type of equipment to be used should be considered in site layout. Compaction equipment should be matched to the fill materials to be compacted as follows:

- Steel-wheeled rollers – suitable on non-cohesive materials such as gravels, but not silts and clays. Vibratory rollers are particularly effective in compacting layers of well-graded gravels
- Tamping (or pad) foot rollers – protruding plates on the roller combines the advantages of both the steel-wheeled and sheepsfoot rollers. Like the sheepsfoot roller, it compacts from the bottom to the top of the lift for uniform density, and like the steel wheel it compacts from the top of the lift. The tamping foot roller is capable of high rolling speeds without throwing material

- Sheepsfoot rollers – protruding studs on the roller drum provide a kneading action. For compaction of plastic soils like clay or silt they are very effective. On granular materials, sheepsfoot rollers tend to shove rather than compact soils. A sheepsfoot roller is required for compaction of cohesive clay materials
- Motorscrapers and excavators – compaction loaded motor scrapers, if available, have the advantage of providing significant compaction along their haul route. The return route of the scraper should be designed to maximise compaction on the constructed bund being formed.

During fill placement operations by an excavator or motor scraper, a separately operated and stand-alone approved roller solely dedicated to compaction should be used to provide continuous compaction during fill placement.

Excavator or dozer track rolling is not suitable machinery for compaction, as tracks are designed to disperse weight rather than concentrate it. Under track rolling, soil layers will tend to not knit together and may result in high air voids. Approved dedicated compaction equipment for the material type must be used to achieve the required levels of compaction. A minimum tare weight of 12 tonnes is generally required for compaction equipment.

6.8 COMPACTION

6.8.1 Compaction Theory

Getting the target compaction at the right water content into the constructed embankment material is the key to providing an embanked pond meeting acceptable stability and permeability requirements.

The relationship between moisture content and density for a given soil under a given level of compaction can be represented by Figure 6.1. These graphs are not universal, they are unique to a particular soil (or mix of soils) under a given compaction effort.

Compaction curves shift up and to the left as the compaction effort increases, for example, by an increase in roller size or number of passes. The black curve in Figure 6.1 demonstrates a higher maximum density being achieved than for the red curve. For the same material, the only difference between the two curves is the amount of compactive effort being applied. Also, note the effect of moisture on achievable density. If the material is too wet, then the maximum density cannot be achieved. For clay embankments, it is better to compact slightly dry of OMC as increased compactive effort can provide a higher density without water being trapped in pores. For sands and gravels, it is better to compact over the OMC as excess water can provide particle lubrication while being able to drain away without pore pressure build up.

A Dry Density/Moisture Content (DD/MC) curve can be produced in a laboratory by wetting up samples at different moisture contents and compacting at New Zealand standard compaction. These samples can also be tested with a shear vane to provide a comparative means to check soil strength and moisture content in the field.

The design process should confirm and specify the minimum construction requirements, such as the number and depth of soil layers, the target percentage of maximum density, and the moisture content required to achieve the necessary soil compaction.

Figure 6.1: Dry Density/Moisture Content Relationship

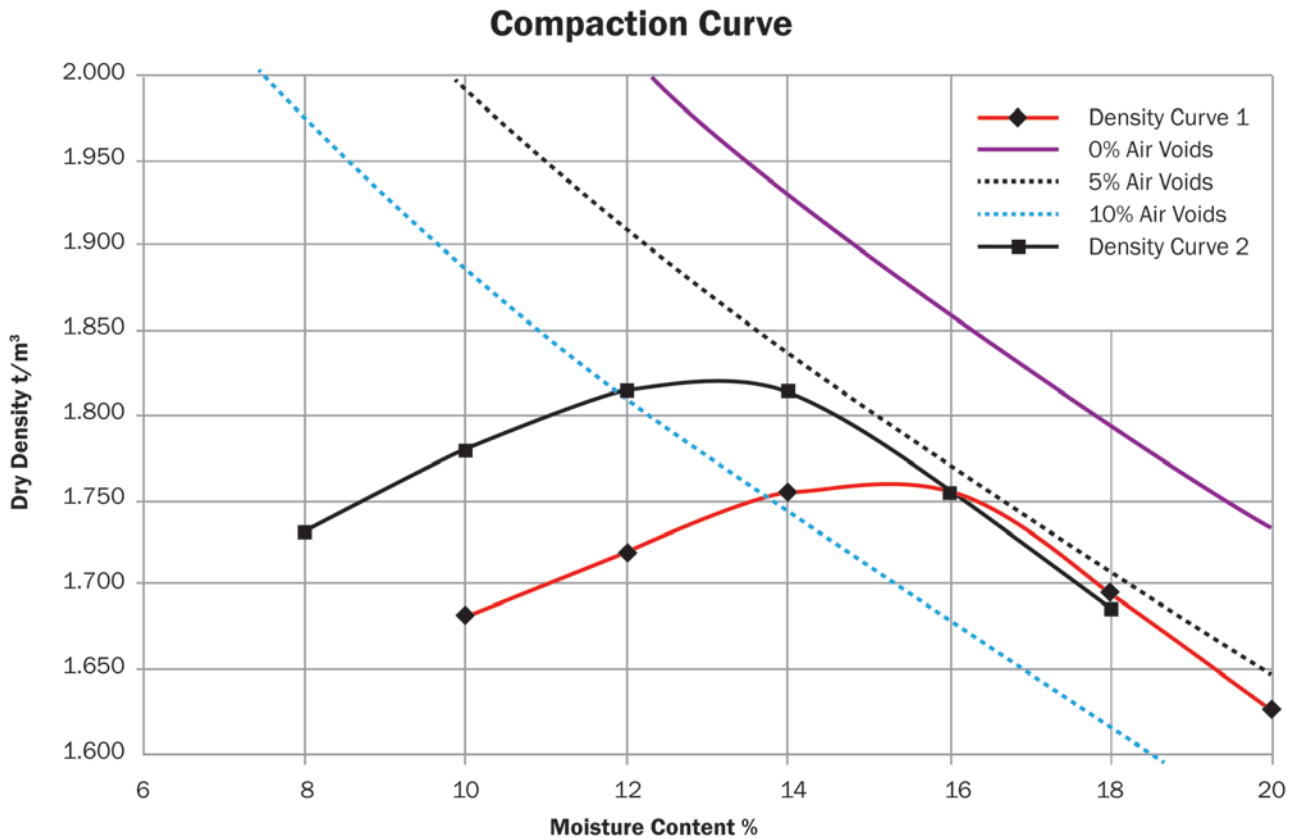

6.8.2 Compaction testing: embankments

Sampling and laboratory testing of the proposed *in situ* fill material to determine the Maximum Dry Density (MDD) and OMC is best done prior to commencing earthworks construction. From these test results the person engaged to carry out construction monitoring may confirm target values. Table 6.1 provides details of standard tests and quantity of testing. These quantities for embankment fill testing are the same irrespective of whether a geomembrane or clay liner are to be installed. For clay liner testing refer Part 2, Table 3.1.

Table 6.1: Embankment Testing

Test	Standard	Minimum rate of testing
Compaction MDD and OMC	NZS 4402.4:1986 Test 4.1.1	One test, but more if material shows any variation
<i>In situ</i> density and voids content	NZS 4407:2015 Test 4.2, Direct Transmission Mode	One test per 50 m ² of surface area of compacted layer, but not less than 10 tests. Minimum of two sets of tests to be taken; at 0% (trial) and 100% of fill placement completion Acceptance criteria: >95% MDD and ± 3% of OWC < 6% voids

Alternatively, if MDD results are not available or the fill material is different from the test results available, the person engaged to carry out construction monitoring may predetermine the compaction requirement by compaction trial.

The contractor should obtain acceptable test results from an IANZ accredited testing laboratory, or another approved agency. Other measurements to show that the construction is being carried out in accordance with the drawings and specification need to be checked by the person engaged to carry out construction monitoring. The contractor must supply copies of test results, certificates etc, to the person engaged to carry out construction monitoring to confirm that materials or works comply before progressing to the next phase of construction.

6.8.3 Compaction trial

A trial strip using the proposed each cut-to-fill or borrow-to-fill material is recommended. This is to determine:

- The effectiveness of the contractor's equipment with the proposed fill materials to achieve the specified compaction density by using a nuclear density meter (NDM) in comparison to the DD/MC test report provided by the person engaged to carry out construction monitoring
- The number of roller passes necessary to achieve the specified density.

For clay materials, Scala Penetrometer and shear vane readings on the completed trial embankment may provide a useful reference tool for subsequent compaction control, but should not be used for fill compaction acceptance purposes.

The contractor's specification should indicate that the contractor will arrange, and pay for, all labour, plant, and materials required to construct and test the trial embankment. If this service is required, it should be clearly stated in the contract documents.

6.8.4 Construction good practice

- It is desirable to keep topsoil separated from subsoil materials during excavation. Topsoil material needs to be placed in a location where it can be accessed after excavation has been completed.
- Material should be placed and compacted in progressive, uniform horizontal layers not exceeding 150 mm compacted thickness. Careful attention is required to ensure foreign material not intended for compacted fill layers is not mixed with fill material to prevent modifying the properties of the intended fill material.
- Pond banks and crests are best formed by over-constructing and trimming back later to the required level and slopes. Final trimming and static rolling is required to produce an even and tight surface.
- The finished top bank width should be more than the roller width. For safety, the bank should be made over dimension so that the roller does not need to work right to the outer edges of the bank since these will be trimmed back later. The crest (embankment top) should also be slightly sloped back throughout construction to prevent rainfall flowing back into the pond.
- Compaction should not continue if the material shows signs of heaving or weaving excessively. In this situation, the material should either be left to dry naturally or, where work progress would be affected by a delay, the material should be dried to a moisture content at which heaving and weaving does not occur.
- Fill surfaces and materials must be protected from becoming wetter than OMC. If materials become wet, continuing with compaction becomes counterproductive and the required soil densities will not be achieved. Valuable time will be lost in waiting for excessive built-up pore pressures (as evidenced by surface heaving and rutting) to dissipate. The moisture content to achieve optimum compaction needs to be continually monitored during construction.
- It is good practice to seal off and slope surfaces away from the works at the end of the day or at the onset of rain. Wet material can be dried either by mixing in drier material or spreading out the wet material in a loose state on a warm or windy day to allow drying. Careful mixing in of small quantities of bentonite can also be beneficial with some materials.
- After the bulk earthworks have been completed, topsoil should be placed on the back-slope surface and sown out in grass to provide erosion control. Any shrubs or trees (including their roots) need to be cleared well back from the embankment.

6.9 EXPOSED BATTERS

The exposed batters and crests of embankments should be top soiled and revegetated as soon as possible after construction, then grassed, hydro seeded, or suitably protected to prevent erosion from rainfall, wind, or frost damage.

The back-slope batter may be flattened further than the specified slope angle by the placement of excess topsoil and other surplus fill material, but only if it is well compacted, surface-trimmed, and levelled.

6.10 FENCES AND GATES

The construction area should remain stock-proof always and the contractor should note that some temporary fencing may be necessary to achieve this. All temporary fencing needs to be removed by the contractor prior to works completion.

Fences and gates, as an access safety measure, will need to be installed in the locations as shown on the construction drawings either by the contractor or the farm owner/client by agreement.

At project completion, any exposed old post holes require filling, the site should be left in a smooth, tidy surface condition, and redundant fencing-related materials should be removed from the site.

Key Points

- Allow for local weather conditions
- Match appropriate compaction equipment with fill material type
- Monitor compaction, confirm with laboratory testing
- Pay special attention to pipe penetration areas through embankments and liners
- Issue practical completion and Defects Liability Certificates on satisfactory completion of all specified work.

7. CERTIFICATION

7.1 CERTIFICATION UNDER THE BUILDING ACT

As with the RMA, different aspects of the Building Act are administered by regional and district councils respectively.

7.1.1 Certification by regional councils

The focus of the regulation of ponds by Regional Councils under the Building Act is the safety and integrity of dams. Specific regulations and requirements are discussed in section 3.

If a pond is not a “large dam” (as categorised by Table 3.5), then there is no requirement for a Building Consent to be granted by the Regional Council. However, with a structure that is “not a dam” or a “dam”, there is still a requirement for it to be constructed to meet the performance requirements of section 17 of the Building Code.

Compliance with the Building Code for a pond or dam is the responsibility of the farm owner/client enabled by the designer and person carrying out construction monitoring. A physical failure of a pond or dam has the potential to bring about an investigation by the Regional Council, and a pond or dam owner must be able to provide documentary evidence of Building Code compliance.

7.1.2 Producer statements

Building Consent Authorities can request designers and those carrying out construction monitoring to submit Producer Statements to confirm their professional opinion that aspects of a building’s design complies with the Building Code, or that elements of construction have been completed in accordance with the approved building consent.

Further, and to give farm owners confidence that contractors have completed their construction works in accordance with contract requirements, a standard form such as NZS 3910:2013 *Schedule 6 – Form of Producer statement – Construction* is often used for this purpose, and is colloquially referred to as a “PS3 (Construction)”.

Where Chartered Professional Engineers are engaged as the designer or the person carrying out construction monitoring they will need to complete and submit IPENZ/ACENZ Producer Statements PS1, 2 or 4 as appropriate. These statements will be appropriate whether the pond involves a dam or not, and whether the BCA is the Regional or District Council.

Chartered Professional Engineers are bound by ethical guidelines to only engage in work in which they are competent. For links to the IPENZ and Chartered Professional Engineers Codes of Ethical Conduct refer to the IPENZ website.

DairyNZ has developed an accreditation process for companies who are designers of FDE systems. This programme is primarily aimed at FDE land application systems, but not at pond design and construction, and allows industry participation to rural professionals and contractors who do not necessarily have professional engineering qualifications.

Non-IPENZ members will not be able to use IPENZ/ACENZ Producer Statements. The BCA in these cases will need to determine the way in which these designers and people carrying out construction monitoring will show compliance to the Building code.

7.2 CERTIFICATION OF CONSTRUCTION

Prior to contractor engagement there needs to be confirmation from the contractor that they will provide all the necessary documentation for the farm owner/client, with assistance from the designer, to provide the council with evidence that the design has been built according to the consent, where a consent is required.

If a FDE pond is constructed under a NZS 3910 or NZS 3915 contract, then the person carrying out construction monitoring should expect to receive one or more than one completed *Schedule 6 – Form of Producer statement – Construction ('PS3')* from the physical works contractor. As-built plans should also be requested.

If an FDE pond and any ancillary works are to be constructed under other contractual arrangements, for example, the farm owner/client is undertaking their own management of the contractor, a 'PS3' should still be provided by the contractor.

While suppliers and installers of synthetic and concrete pond liners will normally be able to provide their own certification of permeability, clay lining provide a significant challenge. Councils generally do not specify the method or means by which such permeability is to be measured; they typically require certification by the FDE designer that the specified liner permeability rate is not exceeded.

Should a liner be supplied and installed by a different contractor, and separate to the pond contractor's contracted scope of work, then installers of such liners will need to provide their own certification in the form of acceptable warranties and a 'PS3'.

Where components of a structure are supplied by a manufacturer and are to be incorporated into the contractor's works, for example, precast concrete panels, then the BCA may require 'PS3s' for these as part of the Building Consent compliance process before issuing a Code of Compliance Certificate.

7.3 CERTIFICATION UNDER THE RMA BY REGIONAL COUNCILS

The acceptance of the design and construction of ponds in some regions is covered by the Regional Council and left to a FDE designer to use industry accepted codes, such as NZS 4431 (Code of Practice for Earth Fill for Residential Development) and section 2 of NZS 4404 (Land Development and Subdivision Engineering), or specific design principles where applicable. Due to the variability associated with the materials used for construction, some element of specific design is required for each application. NZS 4431, while specific to residential development, does give good guidance on the construction of earth fills for bulk earthworks. However, NZS 4404 should not be used for clay liner placement.

For designers and those undertaking construction monitoring services who are not Chartered Professional Engineers (CPEng), Regional Councils will need to determine how these individuals might demonstrate their competence and what form of documentation will be required to confirm Council's rules and consent conditions have been met.

Key Points

- A competent person needs to be engaged at project commencement for both design and construction monitoring
- Regional and district council compliance requirements need to be met
- IPENZ/ACENZ Producer Statements are a method for showing evidence that designs comply with the Building Code.

8. OPERATION AND MAINTENANCE

8.1 INTRODUCTION

This section provides a summary of items that need to be considered for the effective operation and maintenance of FDE ponds.

8.2 AS-BUILT PLANS

Upon effluent system completion, “as-built” plans of the FDE pond as it was constructed (these may differ to the design drawings) should be supplied to the farm owner/client. These provide a valuable record and assists with operations, inspections, and monitoring. As-built plans should include:

- Key levels of base and embankment crests in relation to a datum (at a fixed starting point), e.g. a level at the dairy shed, so any future settlement or impact of pond cleaning can be assessed
- Location, depth, and diameter of all pipes entering and leaving the pond
- Location of power cables
- Details of any under-drainage and gas drain provision
- Location of subsoil drains and leak detection features.

8.3 OPERATION MANUAL

An FDE operation manual should be prepared and include inputs from the designer, construction contractor, and the equipment and service suppliers. All relevant farm staff should be familiar with this manual. An important aspect is to include when, how and where sludge is to be removed, including:

- A plan showing where and how the pond may be accessed
- How and what equipment may (and may not) be used in and around the pond
- The location where the removed sludge is to be deposited
- The appropriate method and depth of sludge spreading.

The operation manual should also include information on:

- Frequency of pond level testing (will vary depending on if there are stirrers and regular mechanical desludging takes place)
- Contact details for repairers of synthetic liners
- Maintenance requirements for pumps, valves, and mixers
- Vegetation control
- Meeting and monitoring resource consent conditions.

8.4 INSPECTIONS

Regular general pond inspection should be carried out by farm management staff and their observations recorded. Not only do they provide a record of any ongoing changes but they might also be useful for consent compliance purposes. Inspections would often be monthly but may be more often following events such as desludging, heavy rain, or unusual event.

As a minimum, the following items should be checked during an inspection:

- Pond level – is there sufficient freeboard? Consider if it should be as empty as it is. Could there be groundwater ingress raising the water level?
- Maintenance of vehicle access and crest of the pond to allow easy desludging equipment access, including in an emergency
- Synthetic liners – no tugging or tearing is present from anchor trench, no visible or obvious damage to liner
- Clay liners – no excessive erosion, drying, cracking, or damage to liner
- Pipework – check for leaks or damage to pipes
- Bunds – no obvious bund failures or damage
- Modifications – have there been any recent modifications to the pond that have not been recorded?

The New Zealand Society on Large Dams (NZSOLD) publication *Guidelines on Inspecting Small Dams* gives a general overview of what to look for, and why, when inspecting a small dam.

8.5 POND LEVEL MONITORING

Storage pond levels should be monitored regularly together with groundwater heights and sludge depths. Monitoring of these levels allows any seepage losses to be readily detected and remedial actions undertaken. Sudden loss of freeboard requires urgent attention.

Wet swampy patches or particularly lush areas of grass can be indicators of leaks. These should be investigated early to avoid unnecessary further damage to the liner. Changes in colour, appearance, and odour of a pond contents can also be indicators of issues with the system.

The installation of an electronic pond level measuring device has the advantage that it can include a high-level alarm and can be monitored remotely. A simple manually read level indicator that can be regularly checked by farm staff is a minimum requirement.

To regularly monitor groundwater, a shallow slotted PVC pipe installed as close as possible to the pond (without compromising the liner) can be satisfactory.

8.6 POND LEVEL TESTING

All tests whether they follow a simple pond level monitoring test approach, or the more sophisticated Pond Drop Test method, the methodology should consider and record the following:

Preliminary

- Develop and record the proposed test methodology
- Shut off any pond liquid inflows or outflows
- Choose a test period of likely fine weather (and such as when cows are dry when less FDE is being produced)
- Securely fix an accurate water-level recording device at a suitable calm location
- Use an evaporation tray to measure water evaporation over the test period.

Record

- Name of tester and date
- Dimensions of pond – length by width by maximum depth
- Depth and type of lining material
- Depth to groundwater
- Weather conditions and allow for environmental effects
- Calibration of the water-level recorder.
- Testing should run for at least 48 hours continuously.

Calculate

- Graph showing level fluctuations with corrections over the test period
- Calculate change of level per 24 hours.

8.6.1 Simple pond level test

A simple pond level test such as using a ruler with close graduations placed at the edge of the pond will be inaccurate, and therefore unsuitable to confirm that a pond has achieved the permitted maximum leakage rate as set by the Regional Council. However, a carefully run test will confirm if the pond has a gross leakage issue. Leakage can originate from a large single-point of leakage or several smaller leaks in the liner. Theoretically, a test can be carried out at any liquid level within the pond, but the worst-case situation and therefore most appropriate for testing is when the pond surface level is near the maximum freeboard level when any leaks will be more easily detectable. The accuracy that can be expected from a simple test is significantly affected by; wave movement, evaporation, and the limitations of accurately measuring and reading very small changes in level.

8.6.2 Pond Drop Test (PDT)

Generally, and after allowing for evaporative loss, the water drop should be negligible. There are varying allowable maximum leakage rates limits that Regional Councils throughout New Zealand have set for their regions in their rules (e.g. less than one millimetre per 24-hour period). Where known, these have been noted in Appendix A of this Practice Note, but are subject to change.

Several New Zealand testing agencies using accurate electronic measurement technology now provide a Pond Drop Test (PDT) with a reading accuracy of better than 1.0 mm. The availability of this technology has increased interest from some Regional Councils in having FDE pond leakage independently tested to confirm the sealing status of a FDE pond. Further, some have a register of approved testing agencies that PDT reports will be accepted from.

This Practice Note recommends that the following PDT testing minimum requirements be adopted. The rationale for these are also given below in Table 8.1.

Table 8.1: Pond Drop Test (PDT) Methodology

- **Testing is undertaken over a minimum period of 48 hours** This is to allow redundancy in the data set for heavy weather or other unforeseen issues. From this dataset, a minimum of 24 hours of continuous accurate data is essential for test calculation purposes.
- **Continuous readings are taken at not more than 10 second intervals over the entire test period** Effluent ponds can have different inputs over the course of a day and must be fully captured. A simple before and after measurement, or even an hourly measurement, does not provide a result of sufficient confidence.
- **Ponds must be at or over 75% of the maximum design depth before a test can be undertaken** This ensures that much of the working surface area of the pond is tested. If the pond is tested when relatively empty the result cannot be applied to the total volume of the pond and cannot be verified as sealed.
- **The level of sludge or crust on the pond surface during the test should be minimised** While not always possible to have no crust or sludge, this layer may or may not affect the test result by fouling the measuring technology and call into question the rate of evaporation on the pond. For example, does grass on the pond reduce evaporation or increase evapotranspiration?
- **The pond surface is not frozen during any part of the testing** This only applies in some low temperature areas of New Zealand and may cause false results due to expansion of FDE.
- **An anemometer shall be installed for the duration of the test and at no time should the wind speed exceed 50 kilometres per hour (14 m per second) during the test** An onsite weather station allows proof of actual rain data. It can also be used to adjust for environmental effects such as evaporation and atmospheric pressure changes.
- **Any change in pond fluid level over the test period needs to be accounted for** There are many factors that can influence the level of the pond, not just milking wash-down and rain. Each change in level must be accounted for and explained to give a clear picture of why there is evidence of seepage (or not).
- **Reported test result has a total test error of less than ± 1 mm** Allowance must be made for atmospheric pressure and other environmental effects. Calibration in a test liquid for every test is recommended. A high level of accuracy from the test system is needed to give Regional Councils confidence in the accuracy of the results.
- **Review and signoff of the test report from an engineering professional** PDT's must be reviewed and signed off by an engineering professional independent of the testing and calculation. This provides credibility and professional engineering standing to the report if it is legally challenged, and if used to support the positions of either the farm owner/client, the regional council, or other parties.

*Pond Drop Test*

8.7 LEAK RESPONSE

If a pond level monitoring test, pond bund wall seepage, or outflow from the leak detection indicates that the pond may be leaking, then a more detailed investigation will be necessary. The first action should be to pump down the pond's water level as far as possible.

For a synthetic lined pond, clean out the base, then visually inspect the lining. Damage to a synthetic liner can be difficult to observe. While liner damage such as a tear or large penetration by machinery might be easy to see, some damage such as pinholes or defective welds will be less obvious. Inspection and sealed joint testing by the liner installer may be helpful. Alternatively, if the groundwater outside the liner is high, then defects will show as water weeping back into the pond. Repairs to synthetic liners should only be carried out by an experienced liner installer.

Clay liner damage from machinery or erosion will often be obvious. Damage repair to clay liners might involve; light scarifying, placing suitable clay on top and compacting, or if more extensive, ripping and re-compacting the liner. Major repair of clay liners should involve an experienced earthworks contractor and a designer.

8.8 SYSTEM OPERATION

8.8.1 Treatment levels

To ensure that the FDE pond system is operating effectively and treatment levels are maintained, the following measures must be undertaken:

- Carry out desludging at regular intervals
- Correct operation of upstream solids removal to maintain settling
- Diligent use of rainwater diverters to avoid hydraulic shocks
- Maintenance of aeration and/or mixing systems.

8.8.2 Desludging

Monitoring sludge depths is critical to ensuring sufficient room in the pond for heavy rain. As sludge accumulates, effluent capacity reduces, so ponds must be regularly de-sludged.

Pond desludging will be carried out by pumping the contents (enhanced by stirring), or digging out the sludge. Care should be taken to ensure that the desludging process does not damage the embankment or liner. It is recommended that a concrete base be constructed where ponds have been designed to be de-sludged with machinery. The installation of a concrete base is also recommended beneath the pump and/or stirrer to avoid damage to liner.

Sand traps must be cleaned regularly. A programme of sand and grit removal at the front end of the effluent treatment system avoids carryover of these abrasive solids, which have very detrimental effects on pumps, pipes, and valves, and adds to the solids on the bottom of the ponds.

8.8.3 Odours

If an FDE pond becomes anaerobic it may give rise to odour. To minimise the incidence and effect of odour, FDE pond design should consider both location and operational measures.

In a traditional FDE two-pond system there is usually little incidence of odour. This is because the pond crusts over and the floating solids ensure the slow release of gas. Generally, odour only occurs in short duration during desludging.

With a clear water holding pond, solids which could crust will have been removed, but soluble organics and ammoniacal nitrogen remain and the deeper waters will rapidly go anaerobic. Gradual mixing of the effluent within the pond will help aerate the liquid and remove and/or convert the ammonia from the pond. This may lead to a brief instance of odour. At these times, prevailing winds and potentially affected parties in the proximity of the pond should be considered.

Regular desludging, varying the level of effluent, and turnover of liquid within the pond will also help reduce the incidence of odour. Transfer sumps should be operated so that effluent is mixed and pumped daily.

8.9 EXISTING FDE PONDS

If an existing FDE pond is to be used as part of a new or upgraded system, it will need to be demonstrated that it meets the leakage criteria. The FDE pond will also be required to meet the current relevant regulatory standards.

Key Points

- Provide detailed plans and specifications
- Develop an operation manual that includes a desludging plan
- Encourage regular monitoring of pond for leakage
- Stirring the pond can avoid odour
- Keep pond volumes low during summer to allow filling during wet periods when soil saturated and unable to irrigate onto land
- A Pond Drop Test (PDT) can confirm that seepage is within allowable limits.

9. FORMS OF CONTRACT

9.1 SCOPE OF WORK AND ENGAGEMENT

It is important that the farm owner/client clearly understands the scope of work proposed, the programme, and the fee basis for the services being offered by the FDE-related services provider, whether they be a designer, a pond contractor, or a liner installation company. A formal written contract between the parties is recommended. For FDE ponds, clients engaging IPENZ members may use the IPENZ Short Form Agreement for Consultant Engagement.

The scope of services to be provided by the designer and the person carrying out construction monitoring (which will be the same person in many instances) should be clearly documented and agreed to by the client so that there is full understanding by both parties from the outset. If working through a farm management agent, then the engagement, design decisions, project management, and responsibility will need to be clearly defined.

The following elements should be included in the scope of services provided, unless excluded by agreement:

- Evaluation of the existing system if applicable
- Identification of improvement options/advice and best-practice systems
- Survey and geotechnical investigations
- Design
- Tendering and tender evaluation/recommendation
- Construction monitoring
- Documentation for consent applications and compliance
- An operation and maintenance manual.

Research indicates that substantial savings can be made to the total project cost through good definition of the project at the initial stage. If the issues are properly considered and agreed at the start of the project, there is a greater likelihood that relationships will develop positively, greater assurance that the client's expectations can be satisfied throughout the project, and a successful conclusion for all parties.

9.2 CONTRACTOR SELECTION

Where there are aspects of the work which will be undertaken by others, such as supply and installation of pumps to the FDE pond, the working relationships need to be clearly defined, i.e. who is working for who.

Similarly, there needs to be an initial discussion and subsequent agreement around how the physical works/contractor(s) are going to be selected and managed, such as specialist contractors for the pond lining or pump system.

The lead contractor should be made aware that they will be liable for the cost of retesting, including any costs incurred by the person engaged to carry out construction monitoring.

The level of construction monitoring for the pond works should be confirmed early in the design discussions and may be determined by the designer's confidence in the proposed contractors.

Physical works contractor selection can take many forms and it is wise to discuss this with the client first.

If the client has a preferred contractor and does not wish to approach any other contractor, it is still important to prepare and supply the contractor with the following, as a minimum:

- Construction drawings
- Schedule of quantities
- Written agreement (NZS 3910, NZS 3915 or supplier/buyer agreement).

If a client wishes to have the physical works competitively tendered, then either invited tenders or open tenders could be appropriate. A full contract document under either NZS 3910 or NZS 3915 is recommended.

Tender evaluation may be solely based on price; however, in some cases where there is particular complexity, track record and methodology evaluations may be advantageous.

9.3 CONTRACTOR ENGAGEMENT

The farm owner/client, the contractor doing the physical works, and the designer need to have their roles and responsibilities clearly defined before construction work commences.

NZS 3910 (Standard Conditions of Contract for Building and Civil Engineering Construction) is the benchmark for construction contracts that have the designer to the contract defined. It clearly defines the contractual relationship between a farm owner/client, the contractor, and the designer and defines their rights, obligations and communications. Furthermore, it sets out procedures to for issues such as payments, insurance, defects liability, and dispute resolution.

Construction industry leaders promote the use of NZS 3910 in its standard form as an equitable form of contract that is well-tested and fair, and provides certainty to all parties. Given the variability in some effluent pond projects, NZS 3910 also provides an excellent framework to value variations in a way that is fair and reasonable to both the farm owner/client and the contractor.

However, NZS 3910 can be quite complex for some clients used to a verbal contract; and for those not willing, or if the scope of works is relatively small, then NZS 3915 can be used as this still provides the relevant contractual engagements, legal status, and responsibilities of the relevant parties.

In both documents, there are certification records required from the contractor on completion of works in the form of a Producer Statement, which can be found in Schedule 6 of NZS 3910.

A defects liability period should also be utilised to provide a mechanism for the repair of defects not obvious at the completion of physical works. A period of 26 weeks is usually adequate for FDE ponds.

The requirement for the contractor to provide insurance is also important, and provides reassurance to both the client and the contractor if anything unexpected occurs. It is expected that the contractor has the following insurances in place:

- Contract works (for larger projects)
- Public liability
- Plant and machinery
- Motor vehicle third party liability.

The inclusion of liquidated damages is worthwhile and may be appropriate for time or economically sensitive contracts, as is a construction programme and completion date. An allowance for inclement weather is usually provided.

Key Points

- **Clearly define the scope of work offered**
- **Signed formal agreement between designer and farm owner/client**
- **Engage contractors under a formal contract, for example, NZS 3910.**

PART 2

CLAY LINERS FOR PONDS

1. INTRODUCTION

1.1 INTRODUCTION

Clay liners for Farm Dairy Effluent (FDE) ponds can sometimes be an effective and economical method for lining dairy effluent storage ponds. Clay can be highly variable and so it is essential that thorough testing is undertaken prior to and throughout construction of a clay liner. The costs of locating suitable clay sources and subsequent construction will also need to be considered relative to other pond lining options available, such as geomembranes.

It is expected that in the future, older clay-lined effluent ponds on New Zealand dairy farms will come under increased scrutiny by Regional Councils as they tighten their FDE storage containment rules. Presently, compliance with containment rules is complicated by some industry confusion concerning the various terms used in relation to storage ponds. Some Regional Council's rules cite seepage rates or leakage rates, while others use permeability or hydraulic conductivity rates with numbers such as 1×10^{-9} m/s or 1×10^{-8} m/s, while yet others are nonspecific.

Part 2 sets out guidelines for good practice clay liner investigation, design and construction and should be read in conjunction with the whole of this Practice Note.

Key Points

Clay lining of FDE ponds can be successfully completed if the following key points are met:

- Investigations and full laboratory testing of the proposed clay source is undertaken
- The clay liner meets all laboratory test criteria, especially particle size and permeability requirements
- The minimum total thickness of clay liner to meet Regional Council's seepage (leakage) or hydraulic conductivity (permeability) requirements needs to be specifically calculated for each site, but should not be less than 450 mm thick
- The clay is constructed with a minimum of three evenly compacted layers
- Cover or armouring material of sufficient thickness is spread over the clay lining to protect it from scouring, drying out and cracking
- A Quality Control testing programme is undertaken during liner construction to confirm compaction acceptance
- Design and construction personnel required to check and approve the work are actively involved in the project.

2. DESIGN CALCULATIONS

2.1 HYDRAULIC CONDUCTIVITY

Hydraulic conductivity is a measure of a soil's ability to transmit water when subject to a hydraulic gradient. The figure below describes the usual relationship between soil types and their inferred hydraulic conductivity, and drainage capability.

Figure 2.1: Hydraulic Conductivity of Soils (Table adapted from FAO Training Series – Chapter 9: Soil Permeability)

Hydraulic Conductivity (m/s)									
1.E-10	1.E-09	1.E-08	1.E-07	1.E-06	1.E-05	1.E-04	1.E-03	1.E-02	1.E-01
Low pervious		Semi Pervious				Pervious			
Compacted Earth	Most Soils					Drainage Materials			
Compact Clay	Stratified Clay	Clay Loams	Silt Loams, Loess	Sandy Loams	Sand and Gravel Mixture	Clean Sands	Gravel		
Recommended (Clay Liner)			Low pervious						

Notes: This is a general guide only and should not be relied upon. Hydraulic conductivity in soils can vary due to changes in seepage fluid viscosity and soil water content.

2.2 SEEPAGE CALCULATION

The term “hydraulic conductivity” is often used interchangeably with “permeability” when water is the seepage fluid. Regional Council rules usually quote maximum permeability values, as acceptance normally relies on undertaking permeability tests on a clay-liner sample using water as the seepage fluid in the laboratory.

The terms “seepage” and “leakage” rates are also used interchangeably and are a measure of the flux. Flux is the rate of flow per unit area. No liner systems, including geomembranes, are completely impermeable and all will have some seepage, albeit very low. Where the seepage rate reaches a predetermined unacceptable value, then, for descriptive purposes, it might be renamed the leakage rate.

Seepage rate has a direct relationship with the hydraulic conductivity of a soil but also includes the head of pressure that is created by the depth of the pond, and thickness of the clay liner. It is expressed as:

$$v = k \times \frac{\Delta h}{\Delta l}$$

v = seepage (or leakage) rate (m/s)

Note: (v) is also referred to as the flux which is the rate of flow per unit area

k = hydraulic conductivity (also known as permeability) (m/s)

Δh = vertical height from pond surface to base of liner (m)

Δl = liner thickness (m)

Furthermore:

$$q = \frac{\Delta h}{\Delta l} \times A = v \times A$$

q = flow rate (m/s or $litres/day$)

A = area (m^2)

Example:

What is the seepage rate (v) from a pond that has?

Clay permeability (k) = 1×10^{-9} m/s , Pond depth = 3.0 m, Liner thickness (Δl) = 450 mm

$$\begin{aligned} \text{Seepage rate } (v) &= \frac{\text{Hydraulic conductivity } (k) \times (\text{Pond depth} + \text{Liner thickness})}{\text{Liner thickness } \Delta l} \\ &= 1 \times 10^{-9} \text{ m/s} \times (3.0 + 0.45 \text{ m}) / 0.45 \text{ m} \\ &= 7.6 \times 10^{-9} \text{ m/s} \\ \text{or } &= 7.6 \times 10^{-9} \times (1,000 \times 60 \times 60 \times 24) \text{ mm/day} \\ &= 0.7 \text{ mm/day} \end{aligned}$$

2.3 FLOW AND SEEPAGE WITH VARYING HYDRAULIC CONDUCTIVITY

The relationship between seepage rate and typical hydraulic conductivity rates, assuming a constant clay layer thickness, is plotted in Figure 2.2. For illustrative purposes, only, it is based on a water filled pond of theoretical surface area 1,000 m^2 (for example 40 m \times 25 m) \times 3 m deep with impermeable vertical walls. It also assumes that the material under and supporting the clay liner is free draining and does not affect the hydraulic conductivity of the liner.

Figure 2.2: Flow (q) and Seepage (v) Rate with Varying Hydraulic Conductivity (k)

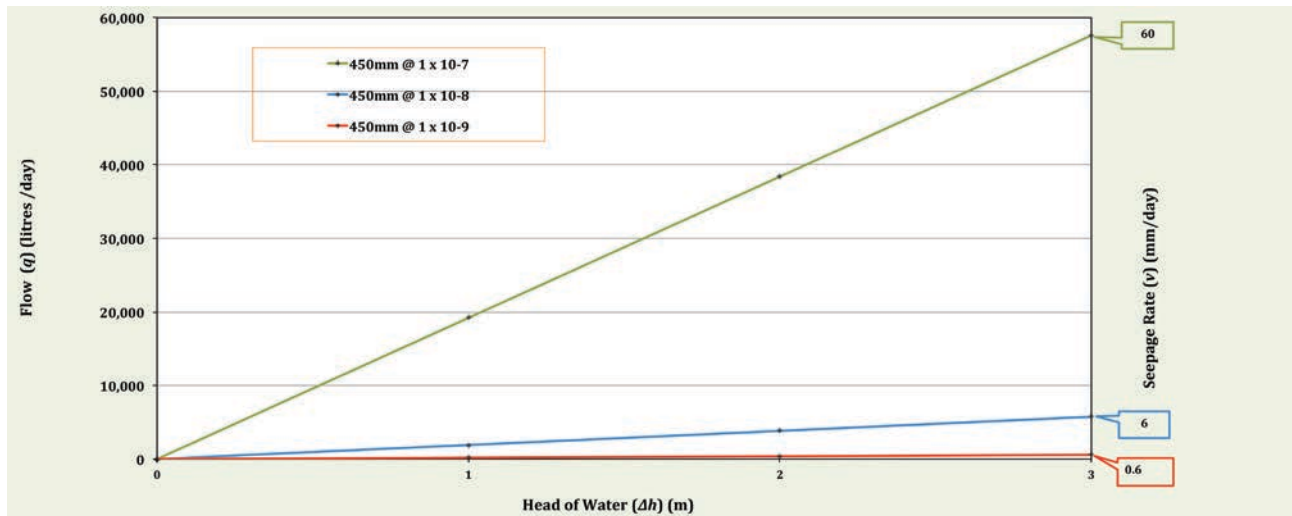

Note that there is a factor of 10 in the increased amount of seepage between each hydraulic conductivity exponent value. For example, $1 \times 10^{-7} \text{ m/s}$ is 10 times more permeable than $1 \times 10^{-8} \text{ m/s}$. Seepage rate also increases with increasing head of water, so therefore a pond that is actively managed to operate at a lower surface level will seep at a lower rate than one that is operated near full.

Again, for illustrative purposes only, Figure 2.3 graphs the effect of varying both clay liner thickness and hydraulic conductivity of the soil, with the head of water up to 3 m. To further demonstrate, the accompanying Table 2.1 shows what the calculated flow rates (q) would be.

Note that seepage rate (v) is independent of the surface area of the pond. However, for a proportionately larger sized pond, the flow rate (q) will be higher as the surface area (A) is used in the calculation.

Figure 2.3: Flow (q) and Seepage (v) Rate with Varying Clay Liner Thickness and Hydraulic Conductivity (k)

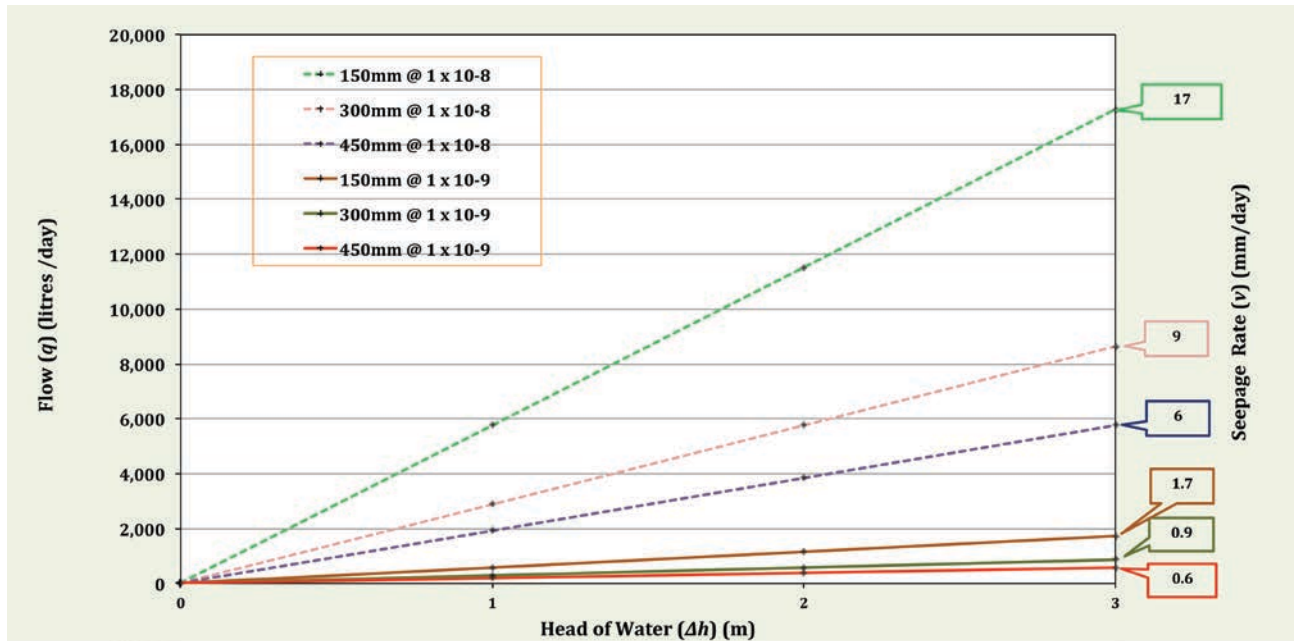

Table 2.1: Flow (q) with Varying Clay Liner Thickness and Hydraulic Conductivity (k)

Clay Liner Thickness (Δl) (mm)	Hydraulic Conductivity (k) (m/s)	
	1 × 10 ⁻⁸	1 × 10 ⁻⁹
	FLOW (q) (litres/day) (with 3m Head of Water)	
150	17,280	1,730
300	8,640	860
450	5,760	580

Note: These are theoretical flow rates through a clay layer. They have been calculated in isolation of material under the clay liner that could affect the seepage rate.

3. INVESTIGATION AND TESTING

3.1 INVESTIGATION

Excavating several trial pits over the proposed borrow-area site is essential to investigate potential sources of clay liner. Materials can be quite variable, even within a short distance. A trial pit allows a large sample of the soil to be logged, sampled and tested. It also provides an indication of other conditions that may affect construction, such as groundwater levels, stability of excavations, *in situ* water contents of the proposed clay and how difficult materials may be to excavate.

(Materials investigations are further explained in Part 1 section 4.4 Field Investigation Steps.)



Investigation trial pit

3.2 LABORATORY TESTING

If it is proposed to use a local soil as a clay liner, then a suite of laboratory tests must be undertaken on representative samples to determine their engineering properties and confirm their test properties meet acceptable criteria.

Table 3.1 provides a guide to the tests that should be undertaken and their test result criteria. The pond designer will need to make their own judgement concerning the numbers of each test undertaken based on such issues as: familiarity with local materials and their performance; size of the pond; material variability; and the proposed pond-liner design.

The suitability of clay materials displaying test values outside of these recommended test result criteria should be subject to specific assessment by a geotechnical engineer.

Table 3.1: Clay liners – Laboratory Tests for Clay Liner Suitability

Test Method	Minimum Test Frequency	Minimum Sample Mass for Testing	Recommended Test Result Criteria
Trial Pits	1 per 500 m ³ of clay, minimum 4 pits		Demonstrate sufficient volume of suitable clay available
Particle Size Distribution NZS 4402:1988 Test 2.8.1 NZS 4402:1988 Test 2.8.4	1 test of each material type	1 kg for clays	>55% passing 0.06 mm >20% passing 0.002 mm Negligible gravel
Plasticity Limits NZS 4402:1988 Test 2.2-1 NZS 4402:1988 Test 2.4-1	2 tests of each material type	500 g	Liquid Limit: 30% – 60% Plasticity Index: 15% – 30%
Linear Shrinkage NZS 4402:1988 Test 2.6	1 test of each material type	500 g	Linear Shrinkage <15%
Standard Compaction Test NZS 4402:1988 Test 4.1.1 NZS 4402:1988 Test 2.1	1 test of each material type	25 kg	Optimum Water Content (OWC) and Maximum Dry Density (MDD) (Water content and shear vane tests at each water content point between –2% to +6% wet of OMC)
Solid Density NZS 4402:1988 Test 2.7.2	1 test of each material type	500 g	Required for Air Voids calculation
Permeability (Triaxial) Test ASTM D5084-03 Method A or, BS 1377:1990 Part 6	1 test of each material type	2 kg	$k < 1 \times 10^{-9}$ m/s Note: some Regional Councils may allow other values, or other acceptance methods (Compaction DD typically at 95% of MDD and +2% wet of OWC)
Pinhole Dispersion ASTM D4647-93 Method A or, BS 1377:5	1 test of each material type	500 g	Non-Dispersive ND1 or ND2

3.2.1 Particle size distribution

Test results from a soil grading (also known as a particle size distribution), is the single most important criteria to consider for clay liner suitability. The grading of soil samples down to silt size is undertaken using sieves to separate the soil into separate particle sizes. The smaller silt and clay sized particles (that is below the 0.063 mm sieve), may require a separate hydrometer test to determine if there is a sufficient percentage of clay size particles present.

Figure 3.1 shows a typical full particle size distribution curve.

Figure 3.1: Example Particle Size Distribution for a Clay-Liner Sample

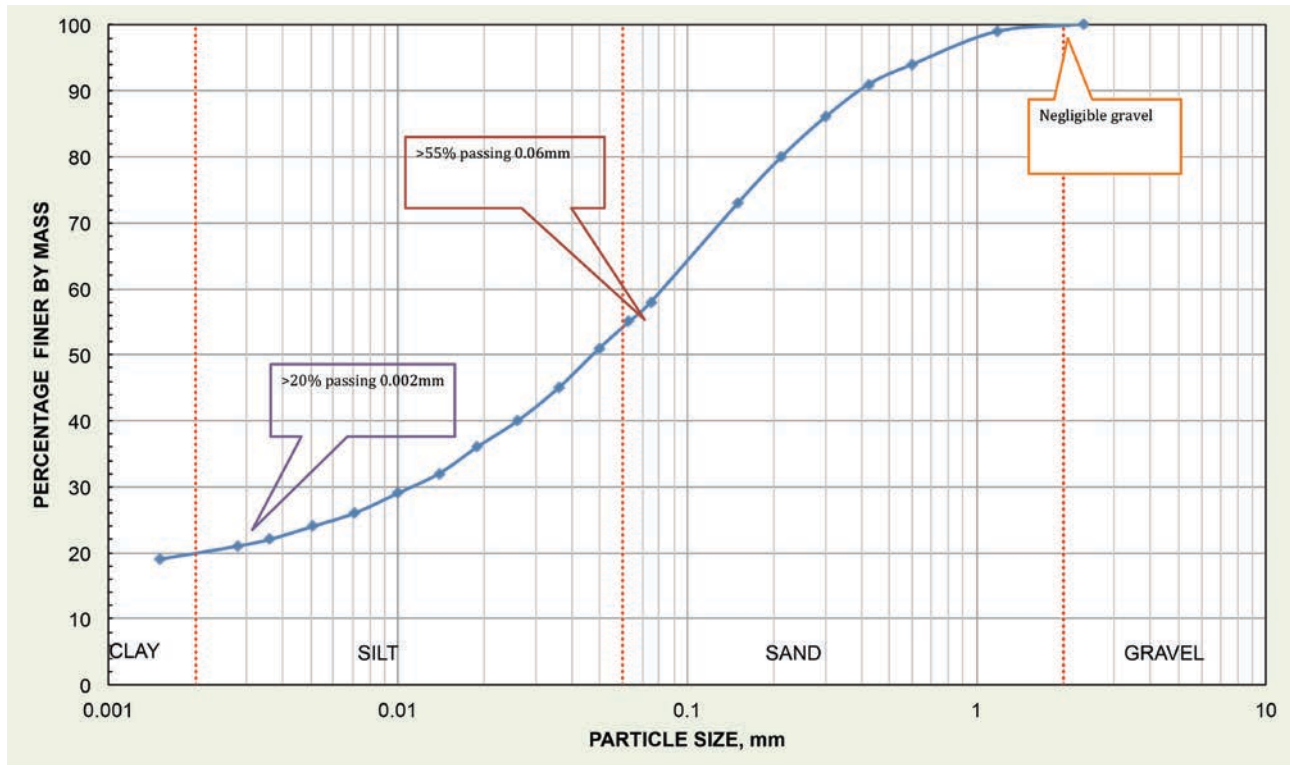

As a guide, a suitable clay liner soil should have:

- Greater than 55% passing 0.06 mm, that is the clay + silt fraction
- Greater than 20% passing 0.002 mm, that is the clay fraction
- Negligible gravel
- Free of topsoil, tree roots and organic matter.

3.2.2 Plasticity limits

If the water content of a clay is gradually dried back from being very wet, the clay passes from a liquid state, through a plastic state, and finally into a solid state. A sequence of tests has been developed to define the boundaries between the plastic and liquid states; these can be used as a basis to classify engineering soils.

Plastic Limit

The transition between a dry crumbly state and a plastic deformable state is known as the Plastic Limit (PL). It is defined as the water content at which a sample of soil begins to crumble when rolled to a 3 mm thread. As a guide, if a finely worked soil with adequate clay content can be kneaded and rolled into a thread of 3 mm in diameter and not crumble, the water content is likely to be close to the Plastic Limit. Being able to roll a finer thread worm than this indicates excess water for optimum compaction.

Liquid Limit

The water content of the soil at the transition between a liquid state and plastic state is known as the liquid limit (LL). It is defined in the laboratory by the water content at which the clay begins to flow under certain test conditions.

For clay lining the LL of the soil should be in the range 30% to 60%.

Plastic Index

The range of water contents within which a soil acts as a plastic material is called the plasticity index (PI) and is defined as:

$$\text{Plastic Index (PI)} = \text{Liquid Limit (LL)} - \text{Plastic Limit (PL)}$$

Soils with very low plasticity ($PI < 10\%$) are unlikely to produce a low permeability clay liner when compacted.

Soils with high plasticity index ($PI > 40\%$) tend to form hard clods when dried, and sticky clods when wet. Highly plastic soils also tend to shrink and swell when dried and wetted up.

The plasticity chart below provides a useful guide to classify soils based on their engineering properties and identifies a preferred range in which a clay liner's plasticity limits should lie.

Figure 3.2: Plasticity Chart for Classifying Fine Grained Soils

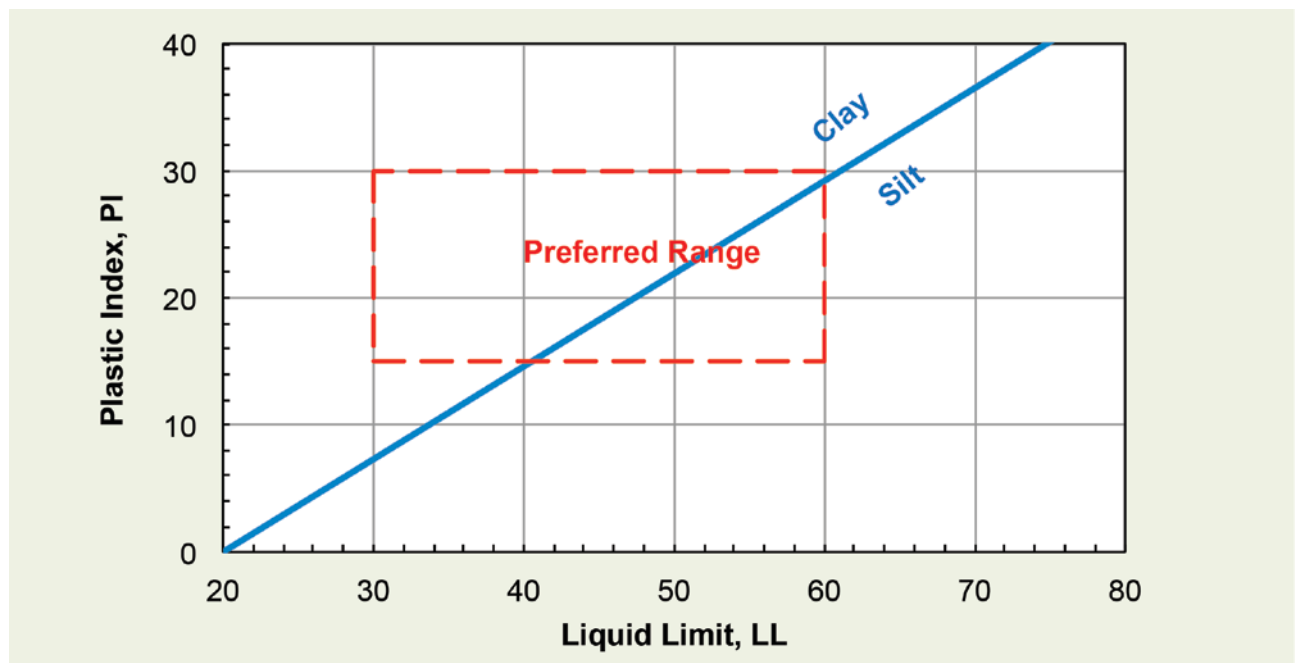

3.2.3 Linear shrinkage

Clays tend to swell and shrink as they absorb or lose water. For FDE ponds, the potential risk is that drying of the clay liner can cause shrinkage and cracking that leads to significant leakage.

The linear shrinkage measures the percentage decrease in length of a soil core as it changes from the liquid limit state to an oven dry state. Clay soils with a linear shrinkage greater than 15% and a liquid limit greater than 60% are considered particularly susceptible to volume change, and hence cracking from wetting and drying.

Less than 10% shrinkage is considered low and is unlikely to be significant assuming satisfactory compaction has occurred at the appropriate water content.

3.2.4 Dispersion

Soils where the clay particles do not readily bind to each other when in suspension are dispersive. Some dispersiveness is required to help sealing, but excessive dispersion leads to leakage through erosion and removal leading to tunnelling. When soils are checked for stability in water their dispersivity can also be observed.

Some clays may be susceptible to erosion into under-drains or into granular bases due to the influence of seepage forces. The pinhole test provides one method of identifying the dispersive characteristics of clay soils. This test method models the action of water flowing along a crack in an earth embankment. The test results cannot be used to calculate the quantity or rate of erosion, but they do provide an indication of potential erosion problems.

Clay lining soils should be tested to confirm that their classification is Non-Dispersive (ND1 or ND2).

3.2.5 Permeability

The permeability of potential clay liner material is best measured in a constant head triaxial cell laboratory test. As the liner soil will be reworked during construction through excavation, spreading and compaction, there is no need to obtain undisturbed samples for investigation testing. However, the preparation of the laboratory sample should reproduce minimum acceptable construction conditions, such as Dry Density (DD) at 95% of Maximum Dry Density (MDD). The laboratory should carry out the permeability test on samples compacted at 2% wet of Optimum Water Content (OWC). Test reports may include permeability at two or more head levels and averaged.

A triaxial constant head permeability test (e.g. ASTM D5084-03 Method A, or BS 1377:1990 Part 6) is recommended because of its repeatable accuracy.

Laboratories accredited for this test can be found by searching under: Testing Inspection Facility, LAB-MECH, 4.08 Soils, ASTM Standards or BS Standards, on the International Accreditation New Zealand (IANZ) database at: www.ianz.govt.nz/directory

Initial indications of soil permeability can also be obtained at sites by filling test holes with water and observing the seepage characteristics over time. This may take the form of falling head, rising head or constant head tests. These tests are not accurate enough to determine permeability's (or hydraulic conductivity) of the order required by Regional Councils for liners.

This document recommends a maximum hydraulic conductivity (k) of 1×10^{-9} m/s be applied for compacted clay if used in forming the lining of FDE ponds. This is the value adopted by many regulatory authorities in New Zealand and represents good practice internationally. Meeting this value can be challenging where local clays are not suitable, and so in many areas geosynthetic liners are preferred.

However, requirements of Regional Council and individual resource consent conditions can and do vary around New Zealand and the acceptance criteria should be confirmed at the commencement of a project.

3.2.6 Compaction

Compaction testing

The theory of compaction along with relevant testing practice is described in Part 1 Section 6.8.

Generally, the higher the soil density the lower the permeability. However, the fabric of the clay soil is also a key factor in permeability, and the target water content to achieve the lowest permeability is found slightly wetter than the Optimum Water Content (OWC).

A Dry Density/Water Content (DD/WC) test will determine the difference in water content between the OWC and the 'as-is' natural Water Content (WC), and how much wetting or drying might be required to achieve the best water content for low permeability. It should be noted that in some New Zealand locations, prevailing weather conditions may make it virtually impossible to sufficiently dry borrow clay back to within an acceptable water content range.

Figure 3.3 illustrates that compacting clay lining at a WC slightly higher than OWC will achieve a desirable lower permeability, despite having a slightly lower dry density.

Figure 3.3: Relationship between Compaction Water Content, Dry Density and Permeability

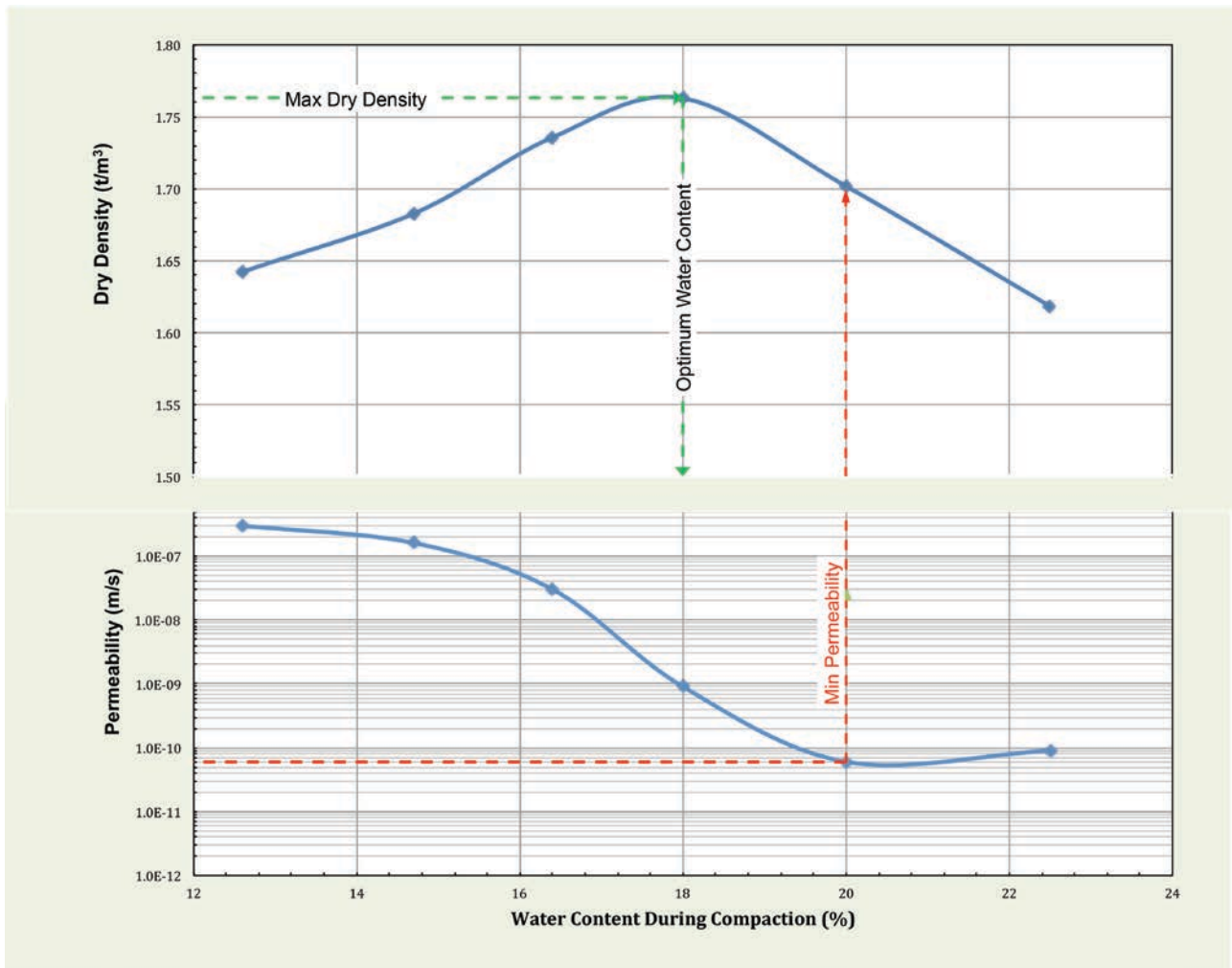

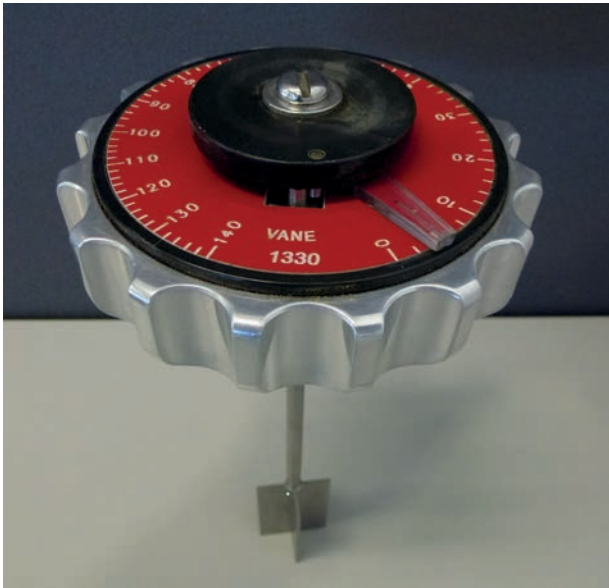

Hand Shear Vane

Shear Vane testing

It is good practice to carry out a hand Shear Vane (SV) test on each compacted sample while undertaking the DD/WC test in the laboratory. These vane readings can then provide the earthworks contractor a comparative means for indirectly checking site compaction.

Compaction acceptance

Prior to construction, compaction acceptance criteria should be set using a combination of test criteria based on both DD/WC and SV laboratory testing, as well as local experience with soils. Your laboratory and specialist designer should be able to provide guidance on this.

The determination of the compaction acceptance criteria is demonstrated in Figure 3.4 and summarised in Table 3.2. Especially note the “Compaction Acceptance Area” in which the average density and WC values (as measured in test lots by the Nuclear Density Meter (NDM)) should be contained within. This area is bounded by five points determined using the following five steps:

1. From the DD/WC curve establish the Max DD. Calculate 95% of this value and draw a horizontal line across the graph. Where this line crosses the DD/WC curve, the WC at this point (Point 1) is the Max WC allowable, if at this WC the SV strength is greater than 70 kPa. If not, then Max WC should be drier and at the WC which corresponds to 70 kPa.
2. From Point 1 extend the 95% MaxDD line horizontally to where it crosses the 5% Air Voids Line; this is Point 2.
3. Extend a line from Point 2 to a Point 3 where the DD/WC and -2% dry of OWC lines intersect.
4. Draw a vertical line upward from Point 3 until it hits the Zero Air Voids line; this is Point 4.
5. Extend a line from Point 4 along the Zero Air Voids curve to the Max WC as determined in step 1; this is Point 5.

Figure 3.4: Determination of Compaction Acceptance Criteria

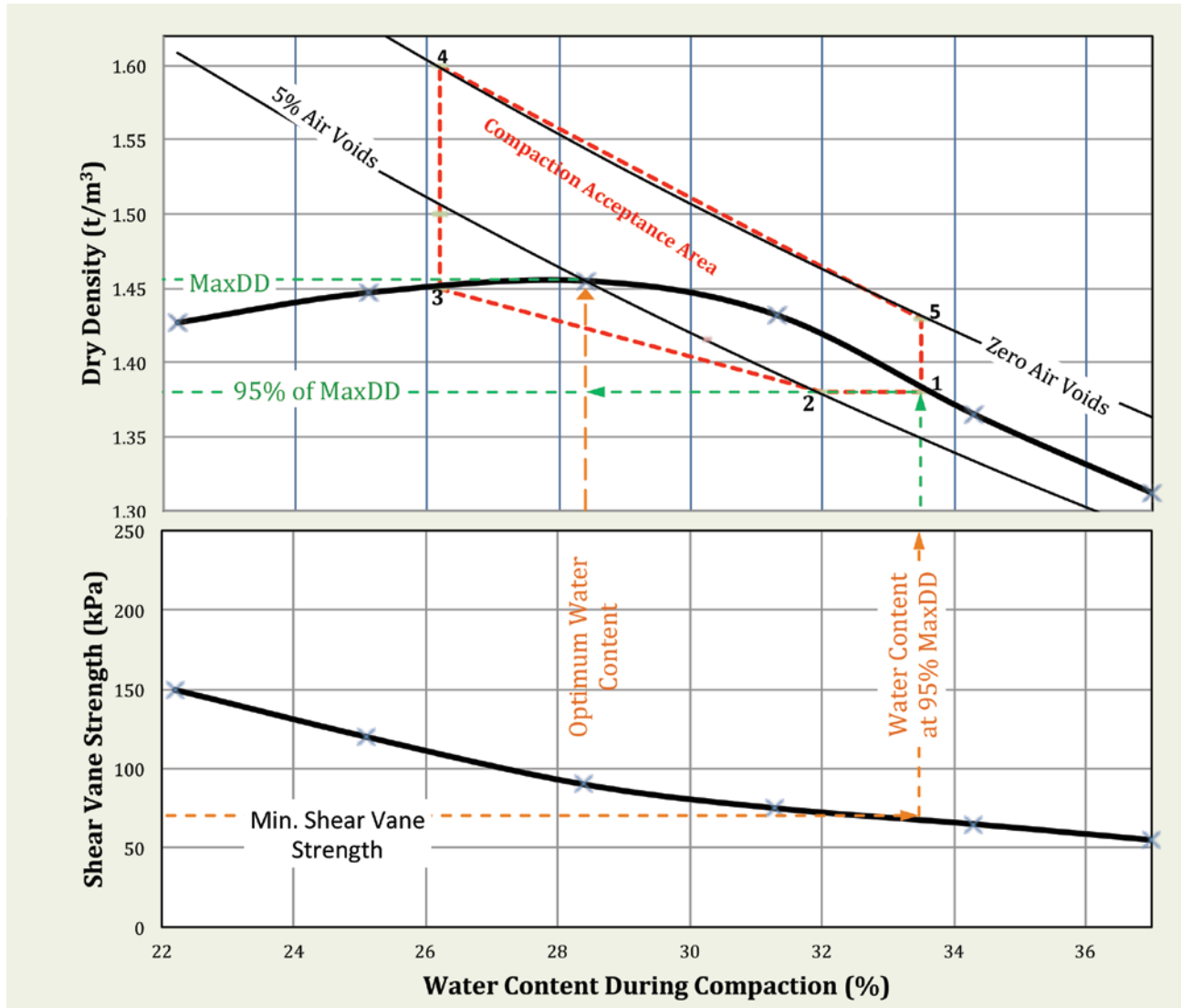

Table 3.2: Compaction Acceptance Criteria

Test	Compaction Acceptance Criteria
Dry Density/Water Content	>95% of MDD
Water Content	Min 2% dry to Max 6% of OWC (nominal)
Shear Vane*	Min 70 kPa to Max 100 kPa
Air Voids	<5%
*SV acceptance criteria takes precedence over WC where SV target values occur inside the nominal WC acceptance range	

4. LINER DESIGN

4.1 SLOPE ANGLES

Most compacted clay soils with a firm to stiff consistency and constructed in horizontal layers will have sufficient shear strength to support slope angles of 2H:1V (27°) for banks up to about 4 m high.

One method to construct a clay liner on these steeper slopes is to build it up in successive horizontal layers. To do this the constructed layer thickness will need to be increased to accommodate the width of construction equipment. As construction equipment cannot effectively compact at the edge of a steep batter, the inner face of the liner needs to be over-constructed by at least 0.6 m and then trimmed back into the well compacted zone.

Figure 4.1: Fill Placement by Horizontal Layers

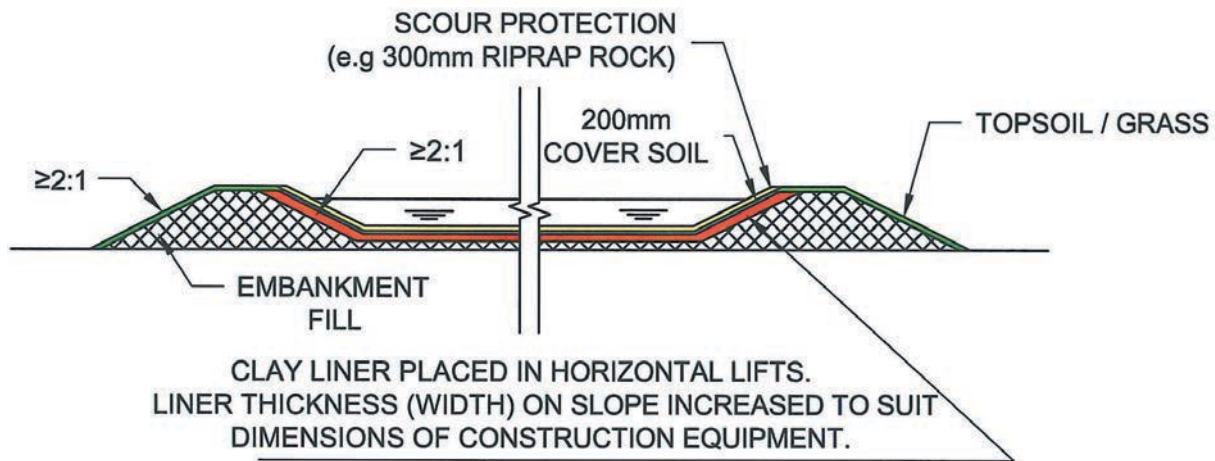

Another method is to construct the layers by working up and down batter slopes. Some compaction equipment will have difficulty safely negotiating the steep slopes while still sufficiently compacting the clay. A flatter batter of 3H:1V, or even 4H:1V (14°), will provide a much higher percentage compaction if this method is adopted.

Figure 4.2: Fill Placement by Up and Down Slope Construction

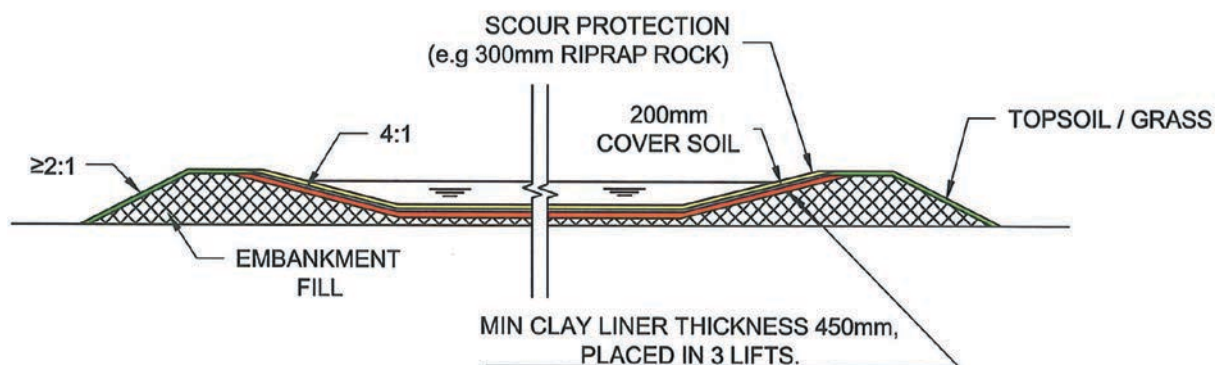

4.2 THICKNESS OF LINER

The rate of seepage through a clay liner is inversely proportional to the thickness of the liner; that is doubling the liner thickness reduces the seepage rate by half. However, most of the leakage from a lined pond is likely to be related to small defects, construction practices or variability in the clay liner material. The design liner thickness must ensure an effective seepage barrier is achieved despite natural variability in clay properties and construction related factors. A minimum thickness of 450 mm is required to practically achieve this.

In addition, the required clay liner thickness should be calculated using the seepage formula in Section 2.2 based on the laboratory permeability test result for the clay to be used and the maximum pond depth. The predicted performance should exceed local Regional Council requirements by a comfortable margin. However, in all cases the liner thickness should not be less than 450 mm.

The liner should be compacted in at least three, and preferably more, distinct lifts each of 150 mm maximum (compacted) thickness, so that any defects or variability in any one lift does not penetrate the whole liner. The upper surface of each lift should be kept moist and not rolled smooth, but lightly scarified so that the lifts are well bonded together and seepage cannot flow along the interface.

It might be argued that in theory a 300 mm thick liner is sufficient, based on a laboratory permeability test result on a sample of clay prior to construction. However, this represents a best-case situation where the compaction and water content on the very small sample undergoing testing is tightly controlled, a situation which can never be replicated in the field, hence the need for the thicker minimum 450 mm layer.

4.3 IN SITU CLAY PONDS

Where the proposed pond location is wholly within a formation of homogeneous *in situ* clay without fissures, layering or other defects which might provide seepage routes, then a slightly different approach is possible. This should be subject to the following considerations:

- *In situ* (natural) and remoulded laboratory permeability test results are acceptable
- The natural water content is close to OWC over the full depth of the pond
- The shear strength is acceptable (generally greater than 70 kPa)
- The site meets other pond siting essentials (See also, Part 1 Section 4.3 of this Practice Note).

For such locations, the construction procedure would be to trim the base and slope of the pond to the required shape and dimensions, scarify and disc-up the top 150 mm of clay to homogenise it, and then recompact it to greater than 95% MDD. A bumpy type roller in conjunction with a smooth drum will be required. Generally, a slope angle of 3H:1V or flatter will be required to achieve an acceptable compaction result.

4.4 CLAY LINER PROTECTION

Designing and constructing the base of a clay lined pond well above the maximum predicted groundwater level is crucial as hydrostatic pressures can easily damage clay liners (refer Part 1 section 4.4.1 of this Practice Note for further guidance). Clay liners are susceptible to uplift from groundwater. Before emptying these ponds it is important to verify groundwater levels are lower than the FDE pond floor.

Clay liners are particularly vulnerable to damage from scour and erosion resulting from stirring, wind or wave action, and need protection. Unprotected clay liners are likely to experience significant cracking if they become too dry (desiccated). Upon refilling the pond, organic solids from the effluent may fill the cracks before the clay can swell and heal the cracks. However, with each season's drying, the cracks will progressively get larger and deeper creating pathways for fluid to pass through.

It is recommended that clay liner slopes be covered with a minimum of 200 mm of moist soil to provide some protection from the exposure effects of wind, wave and sun. This protection must extend over the full height of the side slopes since the pond effluent level will fluctuate during the year. This approach will not be suitable on steep side slopes. Some effluent, or water, should remain in the pond base to keep the clay liner moist.

For protection of areas of concentrated currents or waves, and ponds with long reaches in exposed locations, scour protection is essential, as is rounded internal corners. Similarly, if the operation of the pond creates areas of high velocity currents, for example using stirrers, then specific scour protection, or armouring, must be constructed in these areas. This prevents damage to the clay liner surface from desiccation cracking and erosional scouring by eddy currents as energy is dissipated by the armouring. Armouring should typically consist of a minimum of 300 mm of riprap rock over the 200 mm of protective moist soil. An alternative is to replace the soil with a geotextile (also known as a filter fabric) under the riprap rock armouring, or use a Reno mattress which is a rock filled basket. Concrete facing is another option. Professional engineering advice should be sought for these designs.

Sludge removal activities can damage the clay liner through rutting and tracking of the machinery, and through over-excavation of the sludge. If it is intended to operate vehicles within the pond, such as for de-sludging, the liner should be covered by 450 mm of aggregate. The protective aggregate is placed progressively over the clay surface, by spreading each load from the previously placed area so that the completed clay liner is not disturbed by aggregate placement activity. The aggregate does not need to achieve any particular degree of compaction, but should be dense enough to support vehicle traffic. A reinforced concrete track into and along the pond base, purely to protect the clay layer from excavator track damage, is also an option.

Pipe penetrations through clay liners below the design maximum pond levels should be avoided if possible. Such penetrations, if necessary, should be specifically detailed (refer Part 1 section 5.7.3) of this Practice Note.

4.5 UNDER DRAINAGE

A specifically designed under drainage system beneath a clay liner is critical to ensure that there is no migration of fines into the drainage materials or hydrostatic pressure build up against the underside of the liner.

If clay is placed on top of more permeable soil, such as gravelly soils or subsoil drains, there is a risk that clay particles will migrate into the more porous material through the influence of seepage pressures. To prevent this, a filter layer should be placed between the clay and porous underlying material.

Soil filters are specified by their particle size distribution. The particle diameter of the smallest 15% of the filter soil (D_{15}) should be less than the limits in the following table.

Table 4.1: Soil Filter Criteria

Grading of Clay Liner Soil	Filter Criteria
>85% passing 0.06 mm	D_{15} filter < 9 x D_{85} liner
35% – 85% passing 0.06 mm	D_{15} filter < 0.7 mm

As an alternative to soil filters, filter fabrics or geotextiles may be used provided they meet Filtration Class 2 and Strength Class C as set out in New Zealand Transport Agency (NZTA) specification TNZ F/7.

An under-drainage system connected to a leak detection system provides a convenient means of detecting any leakage through the liner and should be seriously considered as part of the pond design.

4.6 SOIL TREATMENT USING BENTONITE

If clay soils are locally available but have marginal permeability, it may be possible to create a complying clay liner by adding a small percentage of bentonite clay. While having low permeability, bentonite also has low strength, and swells to several times its volume when hydrated from dry. It also has a very high LL and PI. The bentonite used should be sodium bentonite supplied in a fine powder form, rather than the more difficult to mix granular or pellet form.

The properties of bentonite and soil when mixed together vary widely and the optimal percentage of bentonite required must be determined by laboratory testing. If the local soil already has a significant proportion of clay fines, a bentonite content of less than 5% may be sufficient. However, a minimum total thickness of 450 mm for the clay liner is still required.

Figure 4.3: Typical Effect of Adding Bentonite on Permeability of Soil.

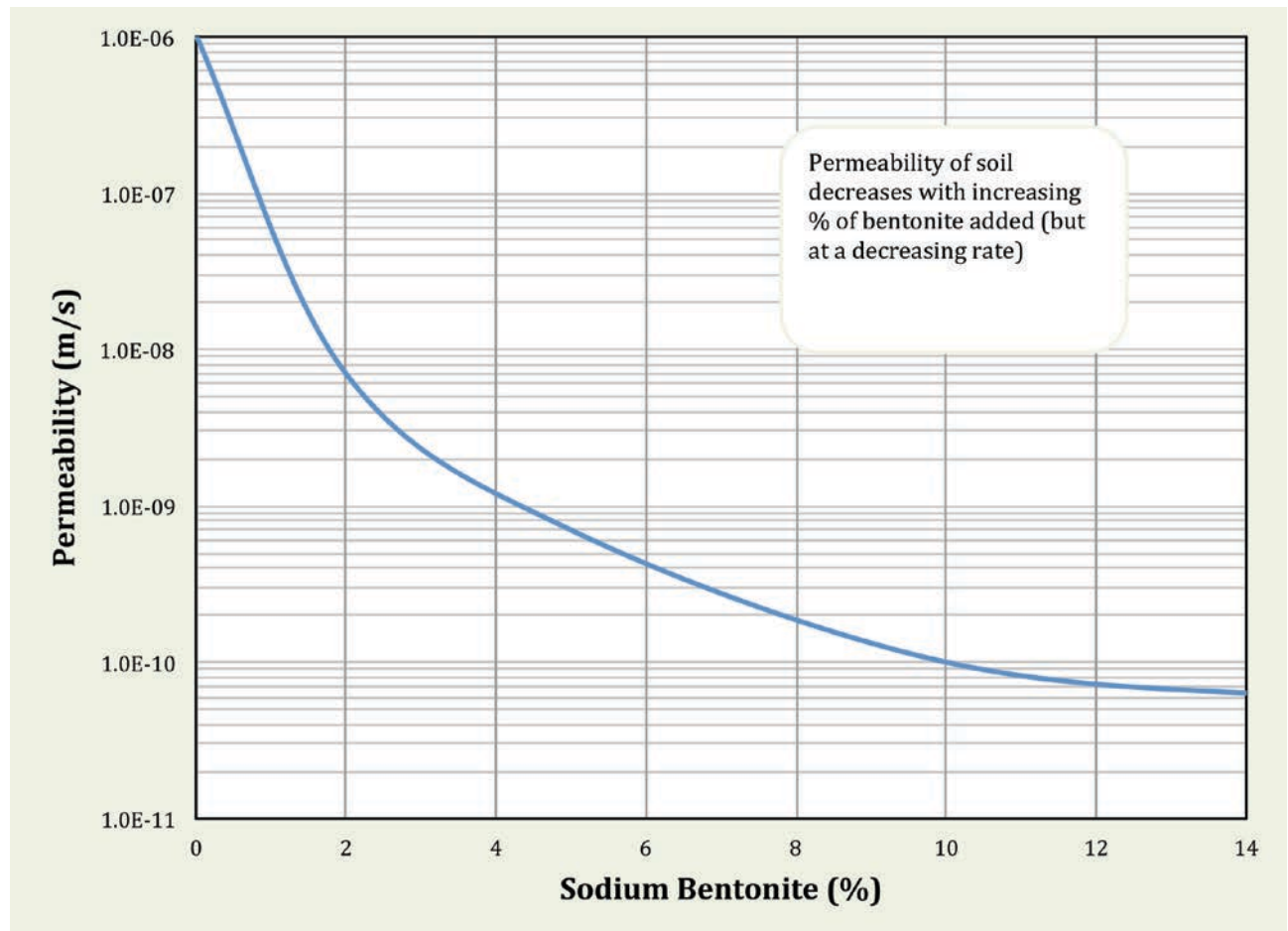

Figure 4.3 shows what typically happens when increasing percentages of bentonite are added to soil. While permeability initially decreases with a small amount of bentonite, the permeability only marginally decreases with further percentages of bentonite added. As bentonite is of low strength, higher percentages of bentonite can be quite detrimental to soil strength. The required percentage of bentonite to achieve a given permeability while still achieving other performance criteria must be established by laboratory testing. Furthermore, a field trial should be carried out to confirm the constructability of a bentonite/soil mixture which will be difficult to add water to and evenly mix in the field.

On-site mixing is done by laying out a carefully controlled even quantity of bentonite with a spreader and mixing in each layer with a highway-type stabiliser or pulveriser. An even higher quality of mixing can be achieved if the bentonite/soil mix is prepared in a pug mill and then transported to the pond. Techniques involving spreading bags of bentonite out on the ground by hand followed by mixing with agricultural equipment are unlikely to achieve a quality liner.

A high bentonite content mix (up to 20%) may however form an effective localised seal around any pipes or structures that go through the clay liner.

4.6.1 Bentonite layers

Applying a thin layer of straight quarried bentonite sandwiched between a prepared surface and a cover layer, with the intention of forming an impermeable layer in a pond, is not a recommended practice for the following reasons:

- The bentonite is not sufficiently confined and will flow when it expands as it becomes damp
- Stones, either above or below the bentonite layer, may penetrate through it during compaction creating a leakage point
- It will not be stable on slopes as the bentonite layer provides a weakness plane for the overlying cover material to slide on
- Thin layers of bentonite are unable to practically maintain an even thickness under placement, levelling and compaction by machinery.

5. CONSTRUCTION METHODOLOGY

5.1 COMPACTION EQUIPMENT

It is vital that compaction equipment is suitable for breaking down the clods of the original soil mass and knits the compacted clay into a uniform tight mass. This is best done with a bumpy drum type of roller, such as a peg/pad foot or sheep's foot roller, with teeth that extend some way through the lift of clay currently being compacted. The roller can be towed or self-propelled.



Self-propelled Padfoot Roller

Agricultural discs may be used to break up clods of soil and to promote drying of wet clay in a separate area away from pond, but only if there is some confidence that there will be an ensuing period of warm drying weather. They are not suitable for mixing soil/bentonite liners.



Discing

There should be a good bond between successive lifts so that water cannot seep between the layers. If the surface of the previous lift becomes too dry or too smooth, it should firstly be scarified and re-compacted.

5.2 CONTROL OF WATER

No amount of compaction will be sufficient if the water content of the clay is not carefully controlled within narrow limits. The clay water content should not be drier than the Plastic Limit (PL) during compaction, that is it should be always possible to roll a clod of soil into a thin thread.

Likewise, the soil should not be too wet during compaction. Wet clay will be soft and will stick to rollers.

Clay soils shrink when they are dried and can crack. Earthworks contractors should be very careful to ensure that no significant desiccation occurs during or after construction.

Methods to prevent desiccation during the construction phase include:

- Spraying water over the surface of the soil periodically
- Covering the soil with a plastic sheet, weighed down with sandbags, topsoil or similar
- Placing an additional layer of moist soil over the clay liner.

Any areas that do crack should be dug up, the clay replaced or re-wetted, and re-compacted.

Compacted wet of optimum and kneaded with sheepsfoot roller

Clay compacted too dry and not well mixed



Effect of Water Content



Compaction on Clay Liner

6. QUALITY ASSURANCE

6.1 COMPACTION TRIAL

At the commencement of the clay lining construction phase, a trial strip is recommended to determine:

- The effectiveness of the contractor's equipment on the sourced clay to achieve the specified compaction acceptance criteria relative to that previously determined from laboratory testing
- An offset factor to be applied to future Nuclear Density Meter (NDM) readings on the clay liner by comparing the WC from the NDM against samples sent to the laboratory for oven WC testing
- The number of roller passes necessary to achieve an acceptable density for a given layer lift thickness.

Shear vane tests on the completed trial embankment will provide a useful reference tool for subsequent compaction control, but should not be used in isolation of the NDM for compaction acceptance purposes. Acceptance testing on thin clay liner lifts using a scala penetrometer is not favoured as they do not provide sufficient accuracy relative to NDMs and leave a hole through the liner after testing.

6.2 SITE TESTING

Because of the critical importance of the clay liner providing an (almost) impermeable barrier to the seepage of FDE into the underlying material, the quantity of testing required is significantly more than that required for embankment fill placement. To ensure that the required compaction, and therefore permeability of the clay liner will be achieved during construction, a suite of confirmatory field tests are required.

Table 6.1: Field Compaction Testing

Test Method	Minimum Test Frequency	Recommended Test Result
<p>NDM Density with Water Content <i>NZS 4407:2015 Test 4.2, Direct Transmission</i> Water content samples from 10% of test sites should be laboratory oven dried to confirm water content correction from the trial being applied is still correct</p>	<p><i>For each lift:</i> 1 test per 250 m² of liner area</p>	<p>Meets agreed NDM and WC acceptance criteria when used in combination with SV testing</p>
<p>Shear Vane (SV) <i>Guideline for Hand Held Shear Vane Test, New Zealand Geotechnical Society, August 2001</i> (The SV may also be used as a consistency tool to identify areas of concern.)</p>	<p><i>For each lift:</i> 1 test per 250 m² of liner area This test only needs undertaking if WC's are marginal</p>	<p>Meets agreed compaction acceptance criteria when SV used in combination with NDM and WC testing</p>

Each lift of the liner should be tested and approved before placing each subsequent lift. NDMs are the usual method of determining the bulk density and WC of a soil. Dry density is derived from the measured bulk density and WC. However, the WC of some clay soils cannot be measured reliably onsite using the NDM. Laboratory oven dried WCs should be used to determine dry density more accurately, until (and unless) site testing establishes that the WCs from the NDM are reliable.

Direct transmission mode is the preferred method of operating the NDM. For a 150 mm compacted layer a 100 mm probe depth is appropriate.

Nuclear Density Meter for Measuring Density of Compacted Soil



Some clays *in situ* are variable, especially those derived from residual soils or volcanic ash, and may not have a consistent MDD that can be easily used for compaction acceptance. In these situations, it may be possible to establish a minimum shear vane strength to ensure that the soil is adequately compacted and that the WC is not too high. At the same time, there should be a maximum air voids set so that clay soils are not too dry when compacted.

Be sure to repair any defects in the clay liner caused by testing or sampling. The area around NDM probe holes can be carefully dug up and re-compacted, or it may be possible to repair the holes with a bentonite mix rammed down and into the hole.

Records should be kept of all compaction control testing so that the adequacy of construction can be verified, and the person signing off on the construction has sufficient supporting records.

6.3 SEEPAGE TESTING

If there are concerns at construction completion as to whether the required hydraulic conductivity has been obtained, there are several possible indicative approaches available to confirm this. Two of these are the pond level test and core testing approaches. These are not a substitute for proper quality control testing as field seepage testing on a newly constructed clay liner can be difficult to undertake, and can be quite inaccurate.

However, they can also be used as an indicator if there are concerns as to whether an existing clay lined pond is leaking while in service. Any noticeable drop in pond level that is unrelated to operations, or not explained by evaporation, should be considered a possible indication of a defect in the liner system.

Before proceeding the Regional Council's acceptance criteria for clay lined pond seepage should be confirmed. Some councils base their acceptance on pond seepage rate or flux in mm per day (mm/day), rather than the clay liners permeability in metres per second (m/s). Converting from one measure to another requires knowing the pond depth and liner thickness.

For example, Environment Canterbury allows a seepage rate (v) of 1 mm per day. This is not the allowable surface level drop in a pond, but the maximum flux through the wet pond liner basin, that is the total area of liner below the ponds surface at its maximum designed operating level.

6.3.1 Pond level testing

The simple pond level test, requires accurately measuring the drop in the pond level over time and calculating the seepage rate. The geometry of the pond is required to be known, from 'as-built' plans, or determined onsite. It should be noted that the complying seepage rate is often so small that it will be difficult to accurately distinguish between seepage, evaporation, precipitation and other inflows. This method will only detect gross leakage and may not be sufficiently accurate to detect a lower but still non-compliant seepage rate. The methodology is further described in Part 1 Section 8.6.1 of this Practice Note.

The relevant formula is:

Maximum seepage (or flux)

$$v = \frac{q}{A}$$

$$= \frac{\text{Pond surface area (m}^2\text{) } \times \text{ drop depth (mm/day)}}{\text{wet pond liner basin area (m}^2\text{)}}$$

Average conductivity or permeability of the liner may be back calculated from:

$$v = \frac{\Delta h}{k \times \Delta l}$$

For pond seepage acceptance by Regional Councils though, a provider of the more accurate Pond Drop Test (PDT) should be engaged. Part 1 Section 8.6.2 provides guidance on pond drop testing.

6.3.2 Permeability testing on clay core

Randomly selected core samples can be taken by using a thin walled sampling tube, sealing it, and sending it to a soils laboratory where a permeability test is undertaken on the extruded sample. However, these are spot samples only and may not replicate the performance of the whole pond when it is full. Samples need to be taken from the base of the pond where the head of water and hence water pressure will be the greatest.

Once the permeability value is known, seepage rate (v) can be calculated if the average pond depth and liner thickness is known.

6.4 RECORDS AND SIGN-OFFS

It is important that pond owners be given a full set of records for their clay lined pond as they may be requested by their Regional Council for information on the sealing and/or seepage rate for the constructed pond.

Also, note that in some regions a Chartered Professional Engineer (CPEng) may be required to sign off on a clay lined storage pond, so it is essential that they are actively involved in the design and construction monitoring work. Rules and consent conditions should be sighted before construction begins to confirm any specific requirements.

Table 6.2: Records

What?	When?	Who?
<ul style="list-style-type: none"> • Copy of investigation and pre-construction testing • Producer statement – design 	Prior to construction	Designer, construction monitoring engineer, and contractor provides copies of their documents to farm owner/client, and the Regional Council as required by their rules and resource consent(s)
<ul style="list-style-type: none"> • ‘As-built’ plans of the pond which include dimensions, depth, batter slope and construction methodology • Construction testing results • Signed Producer Statements from construction monitoring engineer and contractor 	At completion of pond construction	

PART 3
**GEOMEMBRANE
(SYNTHETIC LINER)
SELECTION**

1. INTRODUCTION

1.1 GEOMEMBRANES

Concerns about Farm Dairy Effluent (FDE) leakage from ‘clay’ lined ponds are increasing dairy farming community interest in synthetic liners as an alternative pond lining option. These products are technically known as geomembranes and are available in many chemistry types. The terms ‘geomembrane’ and ‘synthetic liner’ or simply ‘liner’ are used interchangeably in the industry.

Adding to the choice complexity is the ever-increasing range of geomembrane thicknesses available on the market. Sadly, some FDE ponds have been constructed using very thin, or inappropriate geomembrane types, and their durability and in-service performance has not been as claimed. In many cases a thicker geomembrane better suited to the pond (or tank) design may have provided a more dependable and longer-life solution. Furthermore, the geomembrane liner performance will be affected by other factors such as the smoothness of the surface on which it sits and how well it is embankment anchored.

Currently there are few independently written technical documents available which identify what criteria should be used when recommending or selecting a geomembrane to line a FDE pond or tank. In the absence of independent information, this document seeks guidance from the specifications developed by the Geomembrane Research Institute (GRI) which is the international geomembrane industry organisation.



Geomembrane installation

This note provides good practice guidance in the selection of geomembranes and needs to be read in conjunction with Part 1 of this Practice Note.

Key Installation Documents

The following documentation should be supplied by the installer at completion:

- **Certificate(s) from the geomembrane manufacturer confirming full Quality Assurance (QA) compliance with the relevant approved GRI test specification for the batch from which the installed geomembrane was supplied**
- **Site records, including installers subgrade acceptance, panel numbering and placement, trial welds and seam tests, and other supporting QA documentation**
- **Material warranty for a minimum period of 20 years from the geomembrane supplier, which has been approved by the manufacturer for the stated period prior to installation**
- **Installation (workmanship) warranty from the geomembrane installer for a minimum period of 5 years**
- **Certification by the installer that they have completed their work to the drawings, specifications and any other relevant documents. This certification usually takes the form of a signed Producer Statement.**

2. GEOMEMBRANES

2.1 TYPES OF GEOMEMBRANES

Geosynthetics are available in a wide range of forms and materials, each to suit a slightly different end use. These products have a wide range of applications and are currently used in many engineering situations all over the world.

Geomembranes represent the largest group of geosynthetics. They are thin sheets of material manufactured with specific properties to provide key attributes. Membrane design-life well more than 20 years can be achieved for most applications. Geomembranes can offer the advantages of dependable containment with very low permeability, long life expectancy, fast installation and easy maintenance.

Geosynthetic Clay Liners (GCL) are a slightly different type of geosynthetic. They are factory fabricated thin layers of bentonite clay sandwiched between two geotextiles or bonded to a geomembrane.



Geomembrane with geotextile underliner being installed.

2.2 GEOSYNTHETIC RESEARCH INSTITUTE (GRI) SPECIFICATIONS

The Geosynthetic Institute (GSI) is a consortium of organisations involved with geosynthetics. Its Geosynthetic Research Institute (GRI) has developed material acceptance specifications which have become the default international specifications for geosynthetic products covering a range of chemistry types.

These specifications refer to a range of standard American Society for Testing and Materials (ASTM) test methods. Presently GRI's published acceptance criteria based on ASTM tests are limited to the geomembrane types as quoted in Table 2.1. Presently it excludes Polyvinyl Chloride (PVC), Ethyl Vinyl Acetate (EVA), Ethylene Interpolymer Alloy (EIA), and Chlorosulfonated Polyethylene (CSPE). This is not to say these or other geomembranes cannot be used for FDE applications, rather that presently there are no internationally accepted specifications for them.

New geomembrane types are expected in coming years, but until they have been tested and specification test values set by GRI, or some other internationally recognised authority, their use for FDE is unable to be recommended.

Table 2.1: GRI Specifications for Geomembranes

Geomembrane	Geomembrane Name	GRI Specification
GCL	Geosynthetic Clay Liner	GCL3
HDPE	High Density Polyethylene	GM13
LLDPE	Linear Low Density Polyethylene	GM17
fPP and fPP-R	flexible Polypropylene (non-reinforced and reinforced)	GM18
EPDM and EPDM-R	Ethylene Propylene Diene Terpolymer (non-reinforced and reinforced)	GM21
PE-R	Polyethylene reinforced (for exposed temporary situations)	GM22
LLDPE-R	Linear Low Density Polyethylene (reinforced)	GM25

It should also be noted that a geomembrane's conformance with the relevant GRI specification does not confirm acceptability. A careful judgement still should be made as to whether it is suitable for a particular design application, in this instance as a FDE pond or tank lining.

In the GRI specification each geomembrane type is subdivided into different test acceptance values depending on the standard thickness manufactured. What the GRI specification does not provide guidance on however is what thickness is suitable for differing applications. Where it is likely to be exposed to harsh temperatures, weather and operational use, a thicker geomembrane will usually be more appropriate. In general, though, the thicker the geomembrane, the better performance and durability that can be expected.

For FDE structures including ponds and tanks, the majority view of New Zealand geomembrane suppliers is that the minimum thicknesses contained in Table 2.2 should be adopted. This table also recognises that for manufactured tanks, where geomembranes are cut and edges welded together under factory controlled conditions, a slightly thinner geomembrane could be acceptable.

Table 2.2: Recommended Geomembrane Minimum Thicknesses

Geomembrane	GRI Specification	Recommended Minimum Thickness (mm) PONDS ***	Recommended Minimum Thickness (mm) factory welded TANKS ***
GCL	GCL3	Refer Supplier	N/A
HDPE	GM13	1.50	1.25
LLDPE	GM17	1.50	1.00
fPP-R	GM18	1.14	1.14
fPP	GM18	1.52	1.02
EPDM	GM21	1.14	1.14
EPDM-R	GM21	1.14	1.14
LLDPE-R	GM25	1.14	1.14
PE-R*	GM22	Not recommended for FDE	
PVC, EVA, EIA, CSPE**	N/A	Not recommended for FDE	

* PE-R is not recommended for FDE even though it has a GRI specification because the maximum thickness the specification covers is for a 0.5 mm scrim reinforced polyethylene geomembrane. It is noted that the United States Natural Resources Conservation Services (NRCS) also do not recommend it for wastewater applications in their conservation practice standards Code 521A.

www.nrcs.usda.gov/Internet/FSE_DOCUMENTS/stelprdb1046899.pdf

** PVC, EVA, EIA, CSPE and various other polymers are unable to be recommended presently as there is currently no GRI specification to provide a basis of acceptance.

*** Many manufacturers refer to nominal thicknesses rather than actual thickness. For example, the actual thickness of a 1.14 mm geomembrane might be rounded down and referred to on a data sheet as having a nominal thickness of 1.1 mm.

2.2.1 Warranty and Performance

It is recommended that a minimum 20-year warranty period on the geomembrane product be sought from the supplier, irrespective of its New Zealand location. However, this warranty needs to be supported by the manufacturer. The warranty period given by the supplier must not be longer than that offered by the manufacturer.

In addition, a minimum 5-year warranty on the installation should be expected from geomembrane installers. These warranties need to be in writing and owners should carefully read the conditions and limitations contained in them.

Pond designers should be careful not to rely wholly on supplier assertions that the offered geomembrane will provide sufficient chemical resistance for FDE applications for the required design life. Rather, they need to check the manufacturers standard documentation (or supplementary literature if not in their standard data sheets) to confirm suitability. Note that FDE applications overseas manufacturer's data sheets or product catalogues will usually be referred to as slurry lagoons.

2.3 GEOMEMBRANE SELECTION BY ATTRIBUTES

Depending on their intended location and the type of FDE structure the geomembrane will be installed into, differing relevant criteria will need to be considered by designers. Based on industry practice and opinions, Table 2.3 provides a list of the 10 most critical attributes in the New Zealand FDE context for geomembranes.

This attribute assessment is for general comparative purposes only and is not a substitute for direct communication with individual product suppliers who should be able to provide more detailed information and comment on the suitability of their geomembrane for the application. Due to subtle variations in test methods, comparison of similar materials using data sheets is not generally recommended. Requiring the batch of geomembrane delivered to site to meet the relevant GRI specifications avoids this issue.

Table 2.3: Geomembrane Attributes

Attribute	Comments
1 Ultraviolet(UV) and Ozone Resistance	Geomembrane materials that are designed for exposed conditions must resist the sun's Ultraviolet (UV) degradation as well as the oxidation effects of ozone. UV and ozone resistance is a very important attribute for endurance in fully-exposed applications. Good UV stabilisation, but without sufficient antioxidants to provide ozone resistance, will result in exposed surfaces being oxidised more rapidly.
2 Thermal Stability	Geomembranes meeting GRI standards are stabilised to reduce deterioration due to thermal extremes. The installation methodology however must consider any movement (expansion and contraction) over a 40°C temperature range, especially in fully exposed situations. The reduction of thermal stress by covering should be considered.
3 Flexibility	Flexibility relates to the ability of that product to form, bend, mould, adapt and conform to the subgrade and thereby provide intimate contact with the supporting surface. Flexibility can affect the installation method as some materials can be partially prefabricated and others require the jointing of seams to be completed on site. The flexibility of a geomembrane should not be used to compensate for poor design or site preparation, as some liners that are stretched can have a shorter service life.
4 Elasticity	Elasticity is the ability of a sheet material to stretch under stress, for example over a subgrade protrusion, and regain its shape while retaining its elastic properties when the stress is released. Materials that are scrim reinforced generally handle permanent stress better as they have higher strength and minimal elasticity. Elasticity should not be used to compensate for poor surface preparation. Avoid stiff materials spanning voids and highly elastic materials being stretched to create localised thin areas.
5 Tear Strength	Tear strength is a test property that measures the resistance of a geomembrane sheet material to tearing which may be introduced by a cut or puncture while subjected to tensile stress. The most tear resistant geomembranes are fabric (scrim) reinforced where the woven scrim provides high resistance to tear propagation. Tear strength is considered important to overall durability on all geomembranes.

Attribute	Comments
6 Environmental Stress Cracking	<p>Some 'stiffer' geomembranes are prone to cracking under stress, especially if scratched, cut or abraded, particularly in areas adjacent to extrusion welds or at creases.</p>
7 Puncture Performance	<p>The ability of a geomembrane to resist puncture by stones or debris in the subgrade or overlying soils is generally referred to as puncture resistance. Products which can stretch more before yielding have higher puncture resistance. Reinforced materials demonstrate higher puncture strength due to their scrim reinforcement. Tear strength is also important in overall puncture resistance. Good subgrade preparation is always the key to good puncture performance although geotextile used as an underliner can reduce this risk.</p>
8 Repair in Service	<p>An important attribute to consider is the ability to provide competent repairs after many years of service. Oxidation of the geomembrane surface can affect the ability to provide an effective repair. Some materials can be thermally welded. However, most methods require the surface to be clean and dry, the difficulty of which varies between materials. Permanent repairs should always be completed by experienced installers. Repairs by owners can invalidate warranties.</p>
9 Surface Friction	<p>Surface friction is a measure of the roughness of a geomembrane surface to resist sliding on soils, or a substrate, especially under load. Harder surfaced geomembranes provide low surface friction and require a rough texture for steeper slopes. In these situations, 'textured' polyethylene, as well as elastomeric geomembranes that have a higher surface friction, can be considered.</p>
10 Chemical Resistance	<p>The ability of a geomembrane to resist deterioration from chemicals varies. FDE should not be a concern for most commonly available geomembranes. However, a manufacturer's statement stating the suitability of their product for use with FDE should always be confirmed. Suitability will usually exclude the risks from substances such as hydrocarbons, fats, certain sprays and cleaning agents, and harmful chemicals entering the pond or tank. The likelihood of these contacting with the liner surface should always be considered.</p>

Table 2.4 provides a selection guide as to the “pros and cons” for each GRI recommended geomembrane type for FDE ponds and tanks.

Table 2.4: Geomembrane Selection Guide

Geomembrane Type	Pro's	Con's
GCL	High mass and simple joining system, less weather dependant for installation. FDE solids can be removed with care by an excavator (depending on cover material and compaction used).	Requires specific cover materials that may not be available on site. Slope angles, compatibility with subgrade, and cover needs to be evaluated for every site. Reinforced versions recommended for steeper slopes.
HDPE	Good UV and ozone resistance, as well as chemical resistance.	Poorer performance in thermal stability, flexibility, elasticity, stress cracking and puncture performance.
LLDPE	Good puncture performance and tear strength.	Poorer tear resistance, elasticity, thermal stability and chemical resistance.
fPP	Good UV resistance, flexibility, elasticity, chemical resistance, puncture performance and tear strength, repair in service. Popular for prefabricated liners (e.g. FDE tanks).	Poorer thermal stability, chemical resistance, and tensile performance. Poorer elasticity if reinforced. Can be slightly more expensive.
EPDM	Good UV and ozone resistance, elasticity, flexibility, thermal stability puncture performance, and repair in service. Can be part fabricated.	Poorer resistance to hydrocarbons. Poorer tear resistance. Can be slightly more expensive.
PE-R, PVC, EVA, EIA, CSPE	Not recommended	

3. INSTALLATION

3.1 EXPERIENCED INSTALLERS

Geomembranes must only be installed by competent installers who have been approved by their product supplier to provide this service.

For the protection of both the farm owner/client and installer (or alternatively the main contractor and their membrane installation subcontractor), a contract agreement which sets out the expectations and responsibilities, including payment terms and the completed documentation required from the parties is essential (see also Part 1 section 9).

3.2 SUBGRADE PREPARATION

Subgrade preparation must be accepted by the installer and conform to the geomembrane manufacturer’s requirements prior to installation. Subgrade materials should not contain sharp, angular stones or any objects that could damage the liner or adversely affect its function unless a cushion layer is used.

A cushioning layer should generally be placed beneath all geomembrane liners, and certainly if the subgrade particles contain sharp angular stones, or the particle size is greater than 9.5 mm. The designer in consultation with the contractor should make the decision as to whether a protective geotextile is required, or not, under the liner. Geotextile used as protection should meet the requirements of GRI Test Method GT12(a).

www.geosynthetic-institute.org/grispecs/gt12a.pdf

3.3 ANCHOR TRENCHES

Geomembranes need to be anchored to prevent uplift due to wind or slippage down the side slope.

Figure 3.1: Typical liner anchor trench detail

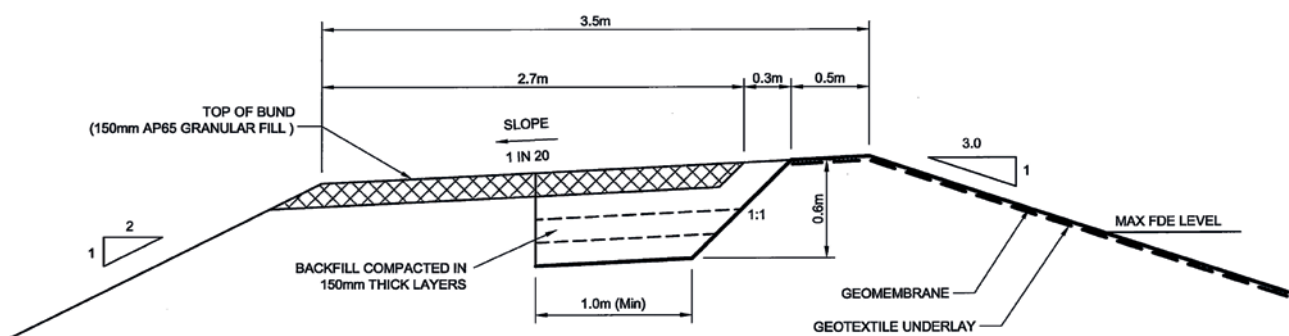

TYPICAL POND LINER ANCHOR DETAIL

3.4 GEOSYNTHETIC CLAY LINER (GCL)

The selection of soil or aggregate cover materials to be placed over the GCL to provide confinement, and the underlying subgrade material, needs to be carefully considered to ensure that high concentrations of potassium, calcium and magnesium are not leached into the GCL leading to material deterioration. GCL is available in several grades depending on the application and pond side slope. Suppliers representing GCL manufacturers should be consulted to ensure the appropriate product and installation methodology is adopted.

3.5 SAFETY

Geomembrane surfaces can be extremely slippery. Geomembrane installation should include appropriate safety features as part of the overall pond design to remove, minimize or isolate hazards. Warning signs, fences, ladders, ropes, bars, rails, and other devices must be provided, as appropriate, to ensure the safety of people and livestock. Requirements of the Territorial Local Authority, Regional Council and Department of Labour should also be carefully considered. Part 1, section 3.2.2 outlines known FDE hazards and controls.

3.6 GROUNDWATER AND DRAINAGE

If the groundwater level is near the proposed base level of the pond, groundwater monitoring should be conducted during the site investigation phase to verify the expected location. The pond should be designed so that it will be well above the highest ground water level expected through the year (See also Part 1 section 5.10.1).

In some situations, it may be necessary to install groundwater monitoring wells for a year or more to determine the ground water levels and gather enough information to properly determine the required flow capacity of the drainage system. If high water tables could adversely affect the proper functioning of the pond structure, such as on a flood plain, an interceptor or relief-type drainage system should be included to control uplift pressures. In these situations, an above ground FDE pond or tank may be a better option.

Subsurface conditions such as soil type and groundwater levels will dictate the direction and scope of the design of the drainage and venting system beneath the geomembrane liner. An inadequate drainage and venting system may result in floating of the geomembrane liner. Hydrostatic pressures from fluctuating groundwater levels or leakage through the liner may cause geomembranes with a specific gravity less than 1.000 to float. Furthermore, if the pressure under the liner is higher than that being applied from above by the stored liquid, the liner will float irrespective of its specific gravity. Also, water intrusion or uplift will impact more on geomembrane types with rigid seams and so become more susceptible to Environmental Stress Cracking.

3.7 GAS VENTING

Gas production and build-up beneath the geomembrane liner due to the presence of organic material in the soil, or leachate leakage through the liner, may cause “whales” or ‘hippos’ at the base of the liner to form (See also Part 1 section 5.10.2).

Therefore, the need for venting should be considered during design for these membrane liners. Site conditions which may be conducive to gas production include sites which have been subject to long-term seepage of animal waste into the foundation soil, sites with naturally occurring organics in the soil such as peat, geothermal areas, or fine grained foundation soils where fluctuating groundwater levels may trap gases present in the soil.



Lining with gas vent.

3.8 DRAINAGE AND VENTING SYSTEM DESIGN

To facilitate collection, drainage of liquids and venting of gas, geosynthetics such as a geonet or geocomposite under the geomembrane liner should be installed to the manufacturer's recommendations. The cut pond base should be sloped, typically a minimum of 2 per cent, to permit positive flow of the liquids or gases. In most cases, the geocomposite will serve both drainage and venting purposes. In very large ponds the base may need to be sloped in multiple directions to decrease the required drainage and venting flow travel distances. The drainage system should also incorporate a leak-detection system and this is recommended beneath all pond lining materials.

3.9 PENETRATIONS

The number of penetrations through a geomembrane lining needs to be minimized. Trenching and backfilling of fill around pipes should be carefully detailed so that subsurface water is not able to flow along the outside of the pipe and down the underside of the geomembrane. Mechanical pipe penetrations and filter collars should be considered. A correctly designed concrete slab around the pipe can be installed to reduce differential settlement along the pipe and reduce a potential weak point around the pipe penetration area.

3.10 STIRRERS

If stirrer or agitation operations are likely to result in abrasion or other mechanical damage to the liner, then protective measures must be provided to ensure the integrity of the lining. Options include increasing the geomembrane liner thickness above the minimum values recommended, or providing protective pads and aprons at agitation locations. A concrete pad laid upon sacrificial offcuts of geomembrane and underliner is a good option as it acts as both ballasting and diffuses abrasive grit agitated by the stirrer.

Floating mechanical mixers and aerators are a risk to the integrity of geomembrane liners, especially when effluent levels are low. Propellers and moving parts must be enclosed within a frame to prevent damage to the liner.

3.11 QUALITY ASSURANCE AND WARRANTIES

It is important that the geomembrane installer prepares a site-specific work plan (also known as a Project Quality Plan) which details the full scope of the installation work to be undertaken. A copy of this plan should be supplied to the farm owner or their representative for acceptance prior to work commencement.

During the project, supporting or confirming documentation for all lining materials supplied and incorporated into the works needs to be gathered. The installers documentation needs to cover all sampling, testing, inspection, and proving of compliance with relevant standards.

At contract completion, and as a contract condition, the following documentation should be supplied by the installer to: the farm owner/client, and to the professional engineer carrying out the design and construction monitoring.

- Certificate(s) from the geomembrane manufacturer confirming full QA compliance with the relevant, approved GRI test specification for the batch from which the installed geomembrane was supplied
- Site records, including installer subgrade acceptance, panel numbering and placement, trial welds and seam tests, and other supporting QA documentation
- Material warranty for a minimum period of 20 years from the geomembrane supplier, which has been approved by the manufacturer for the stated period prior to installation
- Installation (workmanship) warranty from the geomembrane installer for a minimum period of 5 years
- Certification by the installer that they have completed their work to the drawings, specifications and any other relevant documents. This certification usually takes the form of a signed Producer Statement, for example *NZS3910 Sixth Schedule: Form of Producer Statement – Construction*.

4. SUMMARY

There are many factors that contribute to good geomembrane performance, and these are summarised in Table 4.1.

Table 4.1: Factors Contributing to Successful Geomembrane Performance

Geomembrane Success Factors	
Material	<ul style="list-style-type: none"> • Choose a geomembrane with attributes that are suited to the site conditions • Confirm sufficient UV and ozone-resistance provided to suit New Zealand conditions • Confirm resistance to long-term environmental stress cracking • Assure material will not overstretch creating weaknesses • Confirm manufacturer’s product meets GRI specifications • Secure material warranty from the manufacturer for the batch supplied.
Site	<ul style="list-style-type: none"> • Ensure stable-cut side slopes that provide long-term stability • Ensure distance from subsurface organic materials that can form gas • Construct pond base above highest likely ground water level • Install subsoil drainage.
Design	<ul style="list-style-type: none"> • Select competent subgrade construction materials • Develop clear specification for materials requirements • Design for protection against weather extremes • Mitigate stress fatigue and cracking • Include a leak detection system.
Construction	<ul style="list-style-type: none"> • Engage experienced contractors and installers • Confirm subgrade compaction meets specification • Ensure subgrade surface is sufficiently trimmed and smoothed • Confirm anchoring details meet designer’s specifications • Ensure approved sealing around pipes and other penetrations • Adopt manufacturer-recommended jointing/seaming system • Prepare ‘as-built’ plans.
Quality Assurance	<ul style="list-style-type: none"> • Approve Quality Assurance (QA) programme prior to installation • Complete on-site inspection/testing Quality Control (QC) procedures • Documentation reviewed by the design and construction monitoring engineer • Geomembrane supplier provides a warranty (20 years minimum.) • Installer provides an installation (workmanship) warranty (5 years minimum).
Operations	<ul style="list-style-type: none"> • Arrange for regular inspection and maintenance • Have clearly documented cleaning out procedures (if required) • Have procedures for damage repair, including patching repairs • Consult supplier on chemicals and substances which may affect performance • Protect from possible vandalism, stock and other damage causes.

PART 4

PONDS AND TANKS ON PEAT

1. INTRODUCTION

1.1 PURPOSE

Farm Dairy Effluent (FDE) ponds and tanks constructed over peat soils can have an increased performance risk due to the weak and compressible nature of the underlying peat soils.

Anecdotal reports suggest that pond and tank failures on peat have contributed to a climate in which farmers may be reluctant to construct and install dairy effluent storage on their properties.

While tanks and pond embankments may be constructed over peat using procedures and methods outlined in Part 1 of this Practice Note, the engineering properties of peat are such that there needs to be a “step up” in the level of ground investigation and detailed design undertaken. This is necessary to ensure that the long-term integrity and successful performance of these FDE containment and storage facilities are comparable to those constructed over sand, clay and silt soils.

The purpose of this document is to explain the need for this increased level of investigation and design work, and to give some guidance on the choice of investigative techniques appropriate for the intended storage facility type. It is also to identify the issues that need to be considered when choosing construction methods, ancillary works, and the operation of facilities on peat soils. This document is not intended to give design advice, rather to highlight design issues that may need to be addressed by the designer and should be read in conjunction with the rest of the Practice Note.

Key Points

Ponds and tanks constructed on peat soils provide different engineering challenges to those constructed on other soils:

- **Varying rates of settlement across a structure can lead to differential settlement**
- **Ground settlement can continue over many years**
- **Ponds and tanks should be constructed above ground**
- **Gas venting and drainage collection is critical**
- **Clay and reinforced concrete liners are not considered suitable**
- **A “step-up” in ground investigations and design is required**
- **Specialist engineering testing and designer inputs are essential**
- **Design options are available to reduce settlement and performance risks**
- **There may be higher long-term maintenance costs that need to be allowed for.**

1.2 WHAT IS PEAT?

Peat is not a single soil material. It is a highly variable material that can exhibit considerable changes in composition and nature over short distances and depths.

There are several definitions including:

“A mixture of fragments of organic materials derived from vegetation that has been chemically changed and partly fossilised”, and “Dead vegetation in various stages of decomposition”.

Several engineering classifications for peat soils have been adopted reflecting the difficulty in precisely describing and assessing the engineering properties of peat soils.

However, a simplified approach is proposed in which peat is classified into three broad categories based on the presence of roots and other organic fibres within the peat:

- Thick (Coarse) Fibrous Peat (Fibres >1 mm thick)
- Thin (Fine) Fibrous Peat (Fibres <1 mm thick)
- Amorphous Peat (No fibres)

Fibrous peat is generally stronger than amorphous peat, sometimes significantly so. The fibrous crust at the ground surface is often the strongest part of the soil profile in peats.

Peat deposits are typically associated with swamp or bog development in low lying water areas. Many show development profiles like that illustrated in Figure 1.1.

Figure 1.1: Peat Profile in Swamp/Bog Development

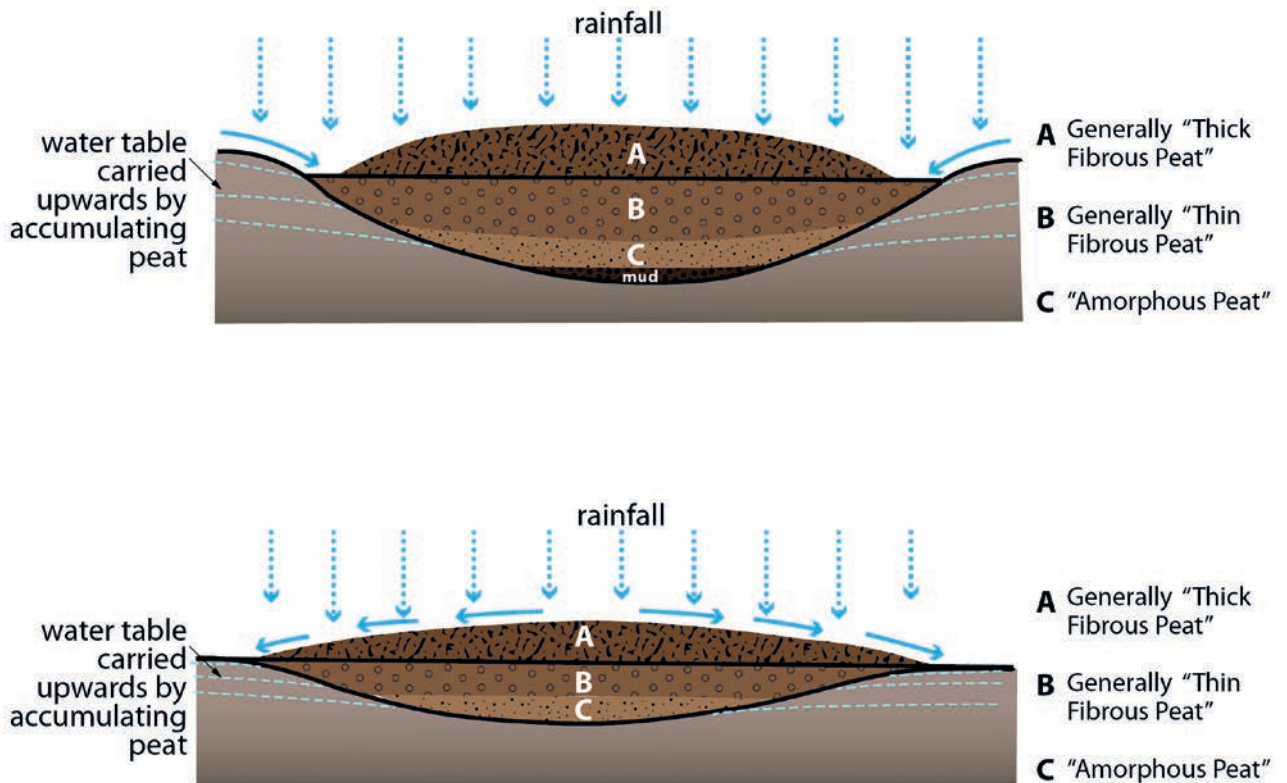

Figure 1.2: Fibrous Peat



The thicknesses and lateral distribution of the three types of peat present can vary and the inflow of streams can result in accumulation of layers of sand, silt and clay within the peat.

For example, a 5-metre-deep peat profile can contain as little as 300 mm of soil minerals and organic matter, the rest effectively being 4.7 m of water held in a sponge-like matrix of decaying vegetation and fibres, and soil particles. By comparison a 5-metre-deep silty clay profile would contain virtually the full 5-metre depth in soil minerals and organic matter.

The figure alongside shows typical near surface fibrous peat. Note the rotation of the fibres from vertical to horizontal towards the base of the photograph. These fibres reinforce the soil lending the peat greater strength than the soil matrix has alone.

In general terms, the strength of peat decreases as the number and thickness of fibres also decreases.

1.3 WHY IS PEAT A CHALLENGE?

There are many reasons why peat can present challenges to construction:

- Peat exhibits many of the same physical properties as other soils such as silt and clay, but it does so to greater extremes
- All soils settle under loadings from pond embankments and tanks, but peat is highly compressible; settlements are potentially much greater and can continue for much longer periods than most other soil types
- Peat can be very weak as well as highly compressible. Paddocks often consist of a relatively strong surface crust which overlies much weaker softer peat below; and if excavation and construction breaks through this crust, the benefits the crust provides can be lost
- Peat soils are typically associated with shallow groundwater and areas of land where groundwater levels can be at, or close to, ground level. This means excavations can flood quickly and the sides of excavations can become unstable
- Peat soils can be comprised mainly of water with very little organic or mineral content. They may contain minimal actual 'solid' material, the rest being water and gas
- The natural variation in peat composition means that each location is different. Variation within the peat beneath a large structure, such as a large diameter tank or pond, may result in parts of the structure experiencing different degrees of settlement. This process is known as differential settlement and can have serious detrimental effects on built structures
- Existing ponds on peat cannot be simply cleaned out and a new liner installed. In many cases, existing ponds that have been excavated into peat are unlined and the effectiveness of their effluent containment is questionable. There are significant health and safety risks associated with entering these ponds, as well as major engineering issues associated with trying to install a suitable liner. Issues are likely to include: groundwater inflow, hydraulic uplift of all liner types, soft compressible soils against which a clay liner cannot be compacted, and unstable sides to the excavation
- Extensive investigations are required to confirm, or otherwise, the continued suitability of a site. Subsequent site specific pond design analysis is required to confirm that the necessary performance from the structure can be expected over its design life
- Investigations need to extend to at least the full thickness of the peat, or to twice the width of the pond bank or diameter of the tank. This is because the loading from the tank or bank is exerted by the soil to this depth as illustrated in Figures 1.3 and 1.4. Peat soils can still be highly compressible even when buried to significant depth.

Figure 1.3: Stress Zones Imposed in Soil by Circular Tanks

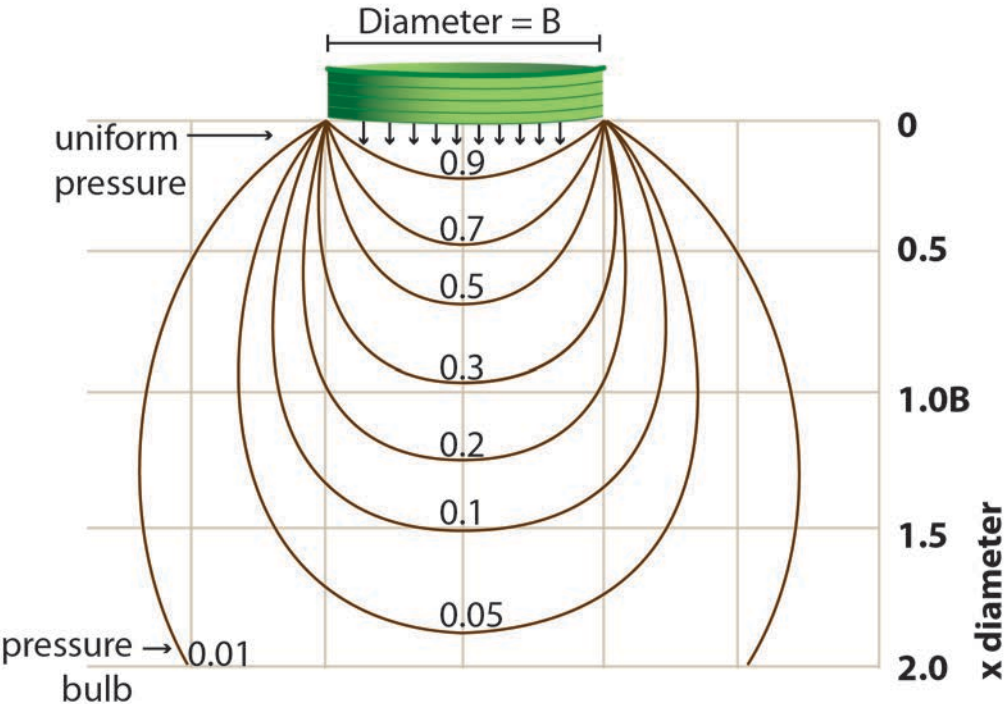
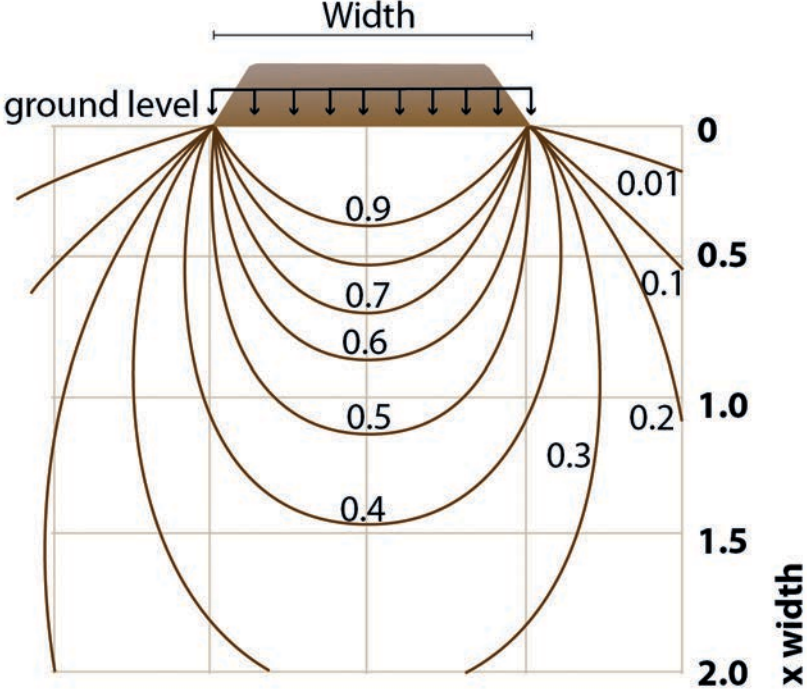

Figure 1.4: Stress Zones Imposed in Soils by Embankments or Bunds



2. ENGINEERING PROPERTIES OF PEAT

2.1 ENGINEERING ISSUES WITH CONSTRUCTION ON PEAT

The key issues that need to be addressed in the design and construction of FDE ponds or tanks on peat are:

- Bearing capacity failure
- Excessive settlement of the structure
- Shallow groundwater table
- Gas collection.

While these issues need to be addressed for construction on all soils, the risks are greater on peat due to its soft and highly compressible nature.

In all cases these issues can only be suitably addressed if an appropriate minimum level of ground investigation is carried out as part of the design process.

2.2 BEARING CAPACITY FAILURE

Bearing capacity failures are caused when the load from a structure, such as from a tank (Figure 2.1) or pond embankment (Figure 2.2), is too much for the soils to support without shearing and giving way under the structure.

Figure 2.1: Bearing Capacity Failure Beneath Tanks

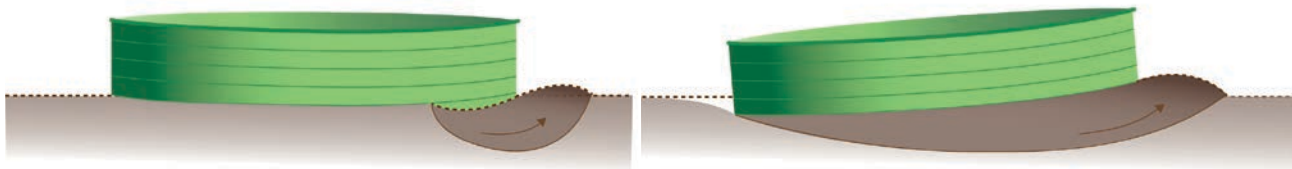
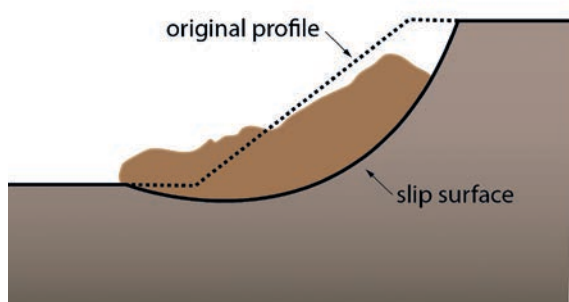

Figure 2.2: Bearing Capacity Failure of Pond Embankment



The shear strength of a soil is the measure of its resistance to failing by shearing or sliding under a load. Peat is one of the few soils whose shear strength generally decreases with depth. The way to avoid these failures occurring is to measure the shear strength profile of the underlying soils and ensure the stresses imposed by the tank or embankment do not exceed the soil's strength.

The generally unnecessary practice of installing shear key trenches beneath pond embankments may increase the risk of a bearing capacity failure on peat soils. Cutting through the stronger crust at the surface of the peat can reduce its integrity consequently.

2.3 EXCESSIVE SETTLEMENT

All soils settle under loading, but settlements are potentially greater with peat. The key issue is to understand and forecast the amount and rate of settlement that will occur over the lifetime of the tank or pond. This is so possible changes in level and shape of the pond or tank can be allowed for in the design process.

The expulsion of water and gas from the soil fabric under the new loading from the tank or pond embankment allows the soil fabric to “close up” causing the ground surface to settle in consequence. This process is known in engineering as consolidation and is equivalent to “shrinkage” in soil science.

Excessive settlement can over-stress and potentially damage liners, disrupt pipe connections, and result in loss of freeboard and capacity in ponds.

Similarly, differential settlement, when one part of the structure settles more than the rest, can cause damage to fixtures and fittings and result in loss of freeboard and capacity in storage structures.

There are two phases of soil consolidation or settlement: a rapid primary phase, and a longer-term, slower secondary phase.

A key difference in settlement characteristics demonstrated by peat over other soils is that the secondary phase does not end. It continues at a constant rate regardless of how heavy the tank or pond embankment is.

The level and rate of the two settlement phases can be estimated from soil test data. This enables the design engineer to allow for the potential effects of these settlement phases in the design and construction of a tank or pond.

2.4 SHALLOW GROUNDWATER TABLE

Most excavations into peat soils will encounter groundwater at shallow depth and are subject to seasonal change.

Groundwater flow into an excavation has a few significant effects, including:

- Flooding of the excavation requiring pumping out, disposal and possible treatment of the water prior to discharge
- Softening and liquefying soils in the base and sides of the excavation
- Weakening and potentially collapsing sides of the excavation
- Lowering groundwater around the excavation, causing settlement of the ground level around the excavation possibly over tens of metres distance.

Figure 2.3: Effects of Excavating Below Groundwater

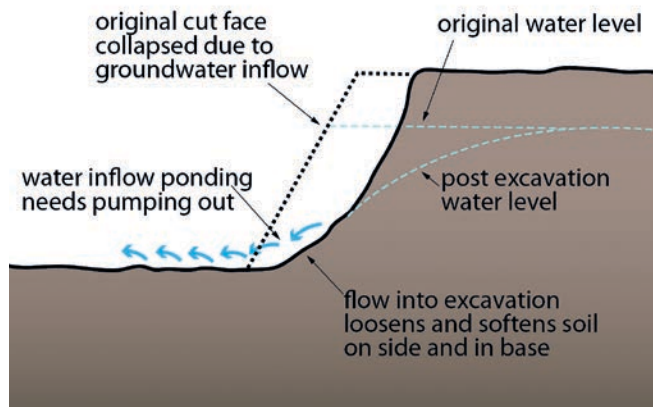

These factors increase the difficulty of working in the excavation and can significantly add to the cost of the works. To avoid these difficulties, pond and tank construction should be above ground, or ideally moved to a location without these issues.

2.5 GAS COLLECTION

The natural degradation of the organic material in peat generates gases, usually methane or carbon dioxide depending on local conditions. If not free to vent to the atmosphere, these gases can collect beneath lining membranes, generating 'hippos' as seen in the photograph below.



Hippo formation due to gas collection

This can be prevented by the installation of gas venting measures beneath a synthetic liner (also known as a geomembrane). However, these venting measures need to be kept dry to operate efficiently and for this reason may be designed to double as a drainage vent if an under-drainage system is installed.

3. SETTLEMENT

3.1 MANAGING SETTLEMENT

A first step during the design phase in managing settlement is to reduce the actual volume of storage required to a minimum. The Dairy Effluent Storage Calculator (DESC) provides a valuable tool in the hands of an experienced designer to achieve this (See also Part 1 section 5.6 on pond sizing for further background). The design of the FDE pond or tank should not be undertaken in isolation of reviewing the whole effluent system. Reduced storage requirements may be possible through factors such as:

- Adopting a low rate application system, which allows irrigation to continue through times when high rate systems are not desirable
- Irrigating to low risk soil areas
- Reducing storage inflows through dry scraping and low water-pressure yard washing, and water recycling such as green wash systems
- Diverting unused shed roof and yard area rainwater away from the effluent storage collection system.

Settlement on peat can be extreme and the aim of managing the settlement is to limit it to a level less than that at which damage could occur to a pond or tank. Several technical means are available to achieve an acceptable level of settlement, although the small-scale nature of individual ponds and tanks often makes it prohibitively expensive.

Never the less there are two common approaches that may be considered:

- If the peat is thin enough, it may be possible to excavate and remove it from beneath the footprint of the tank or pond, or;
- Preloading of the ground surface. This removes much of the settlement prior to pond or tank installation.

Other means of managing small settlements are to adopt construction techniques and materials that can best cope with the deformations and stresses that settlement will impose. For example, geomembranes (also known as synthetic liners) have some advantage due to their flexibility and ease of extending and repairing if necessary; whereas, clay and reinforced concrete liners are not considered suitable as they are usually unable to withstand the imposed forces. The selection of the appropriate synthetic liner material is the role of the design engineer. They should be able to estimate the degree of settlement, including differential settlement that could give rise to deformation and liner stretching. Similarly, pond anchor trenches for synthetic liners must also be properly designed and constructed. Part 3 of this Practice Note provides further guidance.

Settlement of the pond banks may result in progressive “crowning” where the base of the pond rises relative to the sides as illustrated in Figure 3.1. However, subsequent levelling of the peat base by excavating is likely to result in very soft wet peat being exposed following removal of the crust, thereby making installation, or reinstallation, of the synthetic liner very difficult. The design engineer should also consider the loss of storage and freeboard capacity because of leaving the crown in place.

Figure 3.1: Settlement of Pond Banks and Crowning of Pond Centre

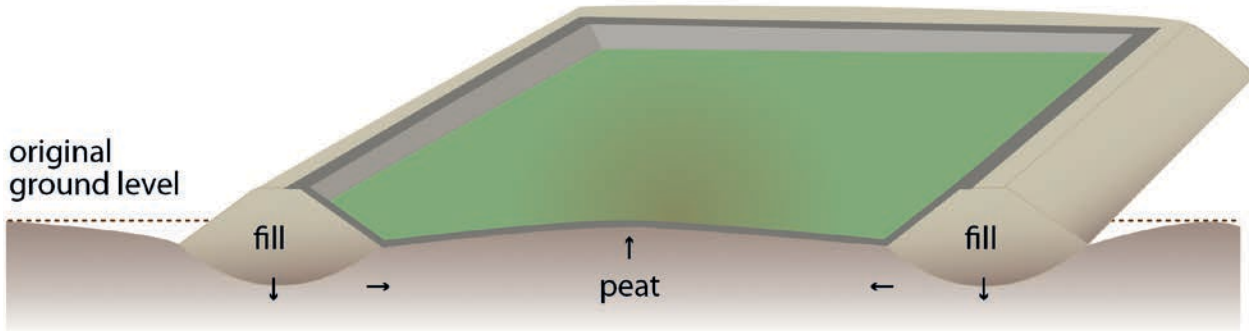

3.2 POND BANK SETTLEMENT

As the largest and heaviest part of the pond structure, pond banks will be the area of the pond in which much of settlement will be generated.

As previously described there are two phases of settlement, primary and secondary, and these are illustrated in an example in Figure 3.2.

In this theoretical example, the ground on which a 2-metre-high bank has been formed, will settle approximately 750 mm in 35 days and 1,000 mm after 10,000 days (27 years). If the predicted, remaining long-term settlement of 250 mm after 35 days has elapsed is acceptable to the pond designer, then the pond can be lined and completed after that time.

Figure 3.2: Calculated Settlement of a Two-Metre-High Bank (Example Only)

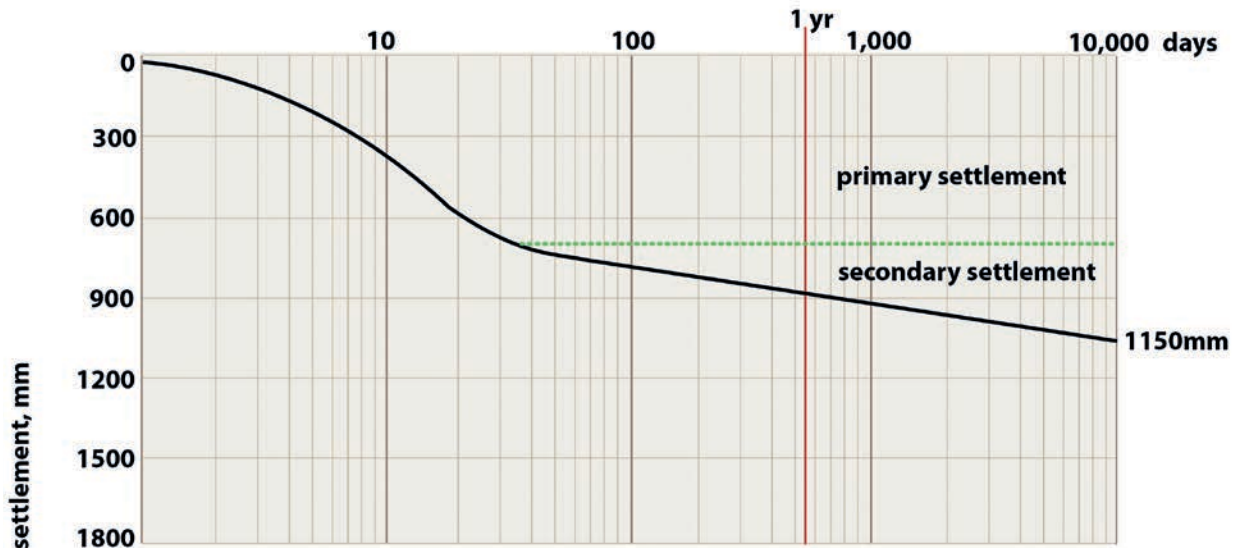

If this approach will not reduce the settlement sufficiently, the designer may consider preloading the ground by constructing a higher, heavier bank to speed the primary settlement, and subsequently remove the extra fill height once 1,000 mm of settlement has occurred. The effect of this is shown in Figure 3.3.

Figure 3.3: Effect of Preloading (Example Only)

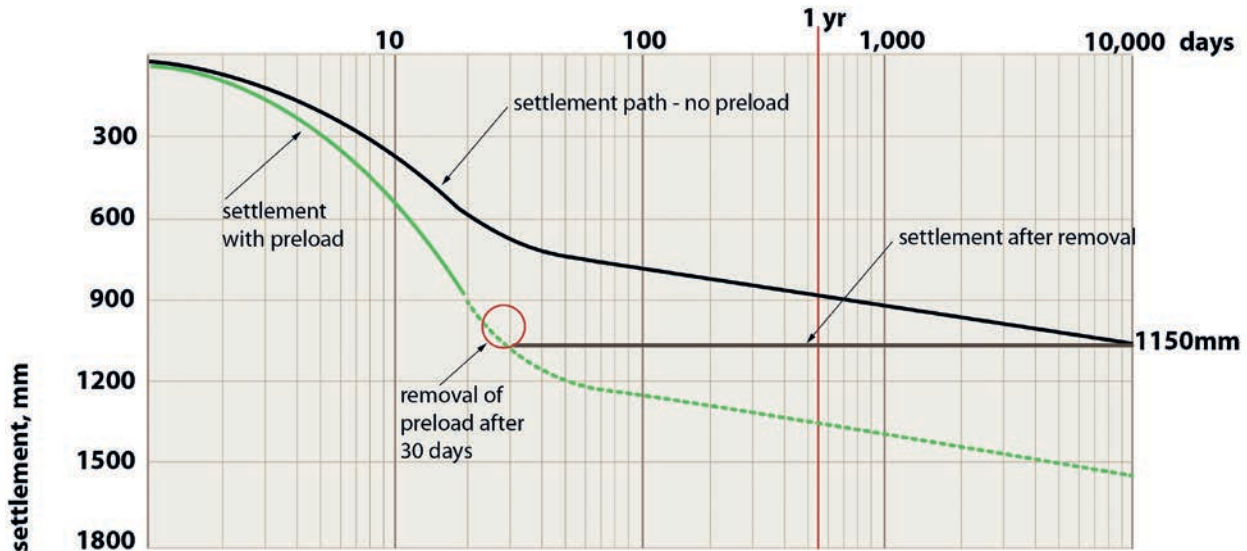

In this example of preloading for a 5-metre-high bank, 1,000 mm of settlement will occur in the first 30 days. If the bank is then reduced by 2 m in height to the finished design height of 2 m above original ground level (the base having settled 1 m into the ground 3 m of fill is needed to achieve the 2 m height above original level), no further settlement can be expected over the next 25 years.

However, there will be a cost to achieve this which will need to be allowed for in the earthworks budget. Specifically, the cost of excavating from a borrow source, placing 3 m of additional but temporary fill to the bank, then subsequently removing 2 m of it and placing it elsewhere.

3.3 TANK SETTLEMENT

Like banks, tanks will settle on first construction following the primary and secondary pattern described above. In general, the degree of settlement from a tank is expected to be less than that of a pond bank as it is a lighter structure.

However, differential settlement around the tank circumference and across the diameter needs to be assessed by the design engineer and consequential stress and strain on liner and tank components allowed for. Standard tank designs will generally cope with a predetermined level of deformation, but the likelihood of deformation beyond that needs to be assessed for the proposed site by the design engineer.

Where excessive settlement or deformation of the tank is likely, preloading the tank site and building the tank on an engineered fill platform is recommended.

3.4 SETTLEMENT DURING USE

Both ponds and tanks will experience further settlement on filling. Each time a pond or tank is filled, settlement will follow the primary/secondary pattern described above. The extent of settlement will be related to the depth/weight of effluent, how long the pond is filled, the size of the pond/tank, and the nature of the underlying peat. In general terms, the cyclic filling and emptying of the pond or tank will generate further settlement in a series of steps over the lifetime of the pond.

4. GROUND INVESTIGATION, DEPTHS AND METHODS

4.1 SCOPE OF INVESTIGATION

In comparison to most other soil types, the properties of peat soils require a “step-up” in the level of ground investigation required. The key issues that need to be determined by a ground investigation on peat are:

- Peat thickness
- Peat strength
- Peat compressibility
- Groundwater level.

Before undertaking any ground investigation, a desktop study of available data should be completed to optimise the onsite ground investigation process.

This should include, but not be limited to:

- Inspection of published geological and soil maps
- Examination of any local water bore records (these are sometimes held by Regional Councils)
- Examination of published papers.

From this information, the appropriate scope and depth of investigation can be determined.

A minimum of three exploratory holes is recommended, located evenly around the perimeter of the proposed tank or pond. This allows interpretation of ground conditions between exploratory holes and beneath the proposed tank or pond. Any variation in peat thickness and consistency across the site should be identified and any consequential risk of differential settlement considered.

4.2 DEPTH OF INVESTIGATION

Tanks and ponds impose loads on soils to a depth equivalent to the diameter of the tank, and width of the pond. As a minimum, the investigation should therefore penetrate the full depth of the peat, or to twice the width of the proposed tank or pond embankment, whichever is the shallower.

Care is needed to ensure that the true base of the peat is reached. Many peat deposits are inter-layered with sand and silt soils which can be mistaken for the base of the peat deposit.

4.3 METHODS

In very thin peat deposits of up to 3 m, investigations by test pitting and field testing, supplemented by scala penetrometer and hand shear vane testing, may be sufficient (See also *Part 2 section 3 for investigation and testing*).

In thicker peat deposits the following methods of investigation should be undertaken.

4.3.1 Cone Penetrometers (CPT)

In thicker deposits, Cone Penetrometer Tests (CPT) and/or boreholes are needed to determine the peat properties over the depths of soil concerned.

Typically, the CPT is carried out from a truck or track mounted rig (Figure 4.1). The CPT itself is a rod fitted with a cone tip that is pushed vertically into the ground at a constant rate. The penetration resistance encountered and the friction on the side of the cone is recorded by pressure and strain gauges fitted to the rods. By comparing the penetration resistance of the cone to the side friction, the soil type and soil strength can be determined continuously by depth. The results are presented as a series of graphs which aid their interpretation (Figure 4.2).

By using a cone fitted to the rod, water pressures are measured as it passes through the soil. The test can be stopped and the time taken for pore water pressure to fall to a background level determined. This is a 'pore water dissipation test' and the results can be used to aid assessment of the rate of settlement.

The CPT tests can be further supplemented by undertaking a limited number of hand shear vane tests in the upper 1 m of the soil to aid assessment of the stronger soil crust.

Overall CPTs offer a cost-effective means of assessing peat strength and compressibility, but as no samples are obtained, the speed and degree of settlement cannot be determined as accurately as by using samples obtained from a borehole.

Figure 4.1: Truck and Track-Mounted CPT Vehicles



Figure 4.2: CPT Results Showing Typical Raw Data for Thick Peat

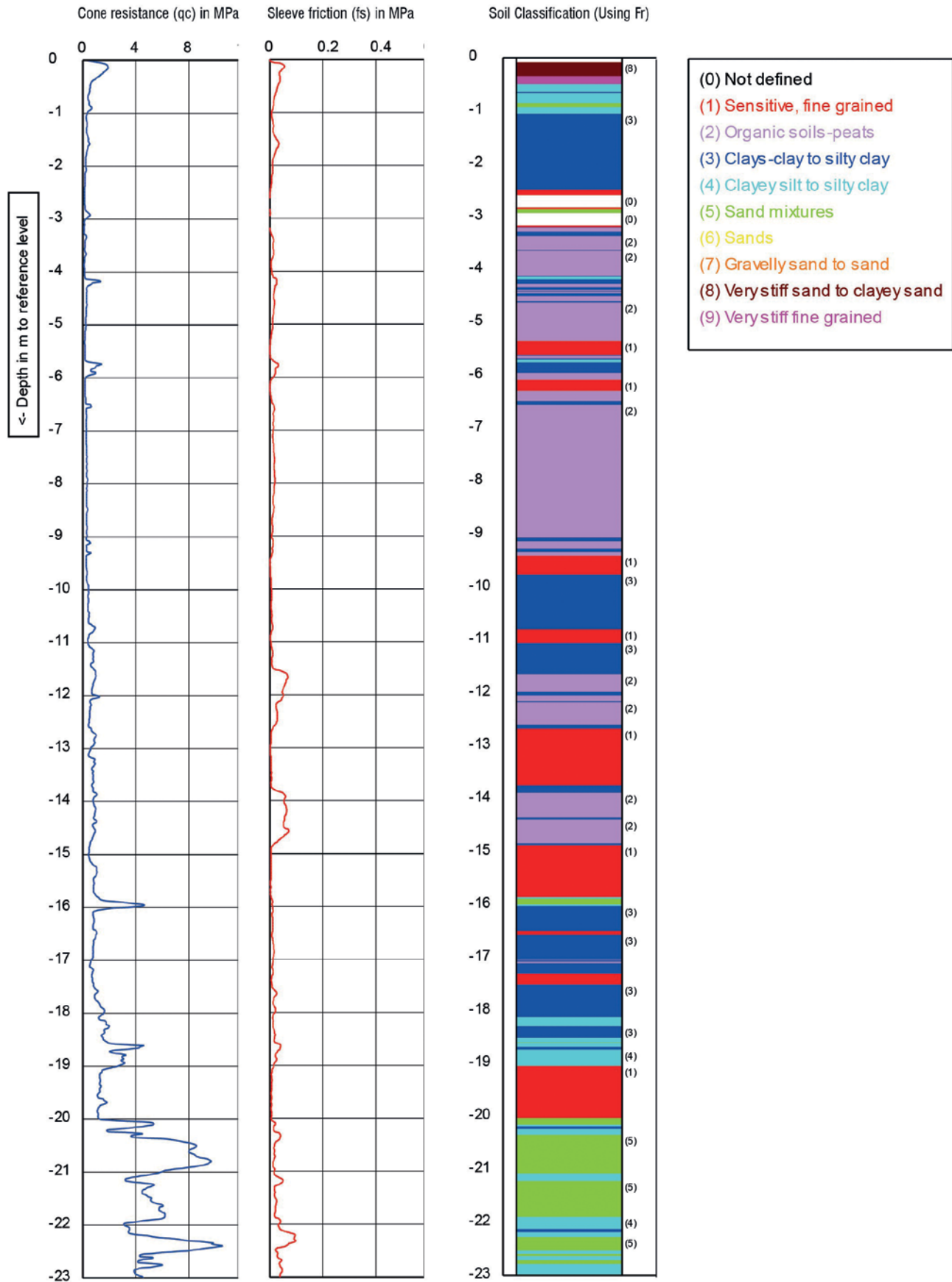

4.3.2 Boreholes

Whilst CPT data can be used to estimate settlements, to fully define and obtain good estimates of likely settlements and particularly the rate of settlement, laboratory testing of soil samples is necessary. The best way to obtain these samples is from a borehole.

Boreholes allow core and tube samples to be obtained from depth that can then be tested for settlement properties in a soil testing laboratory. They allow visual inspection of the soil materials, an assessment of the fibre content and the selection of samples for testing.

The primary soil laboratory test to determine settlement properties is an 'oedometer consolidation test'. The results of these tests can be used directly to estimate the rate and degree of primary and secondary settlements on peat.

Moisture content and liquid limit tests can also be used to indirectly assess peat properties and aid interpretation of the oedometer and CPT test results.

The use of oedometer test data should give the design engineer a greater level of confidence in the assessment of peat properties than that based on data obtained from the CPT alone.

Oedometer tests are very important to gauge the rate of settlement and the timing of some key construction decisions such as installation of liners or if staged construction is necessary.

If staged construction is considered necessary the test results are then used to assess how much surcharge should be applied, and the timing of its removal.

5. DESIGN PROCESS AND CONSIDERATIONS

5.1 COST AND RISK ASSESSMENT

It is important to recognise that some degree of settlement of tanks and ponds on peat is inevitable, but that it can be reduced to manageable levels. Periodic future maintenance work related to settlement can be forecast, planned and budgeted for.

At the investigation phase, with each “step-up” from basic test pitting to CPTs, through to boreholes and laboratory testing, there is an increase in investigation cost but also an increase in the quality of the data obtained for use in design. The relationship between costs and risk is illustrated in Figure 5.1.

Figure 5.1: Ground Investigation Relative Cost and Risk Comparison

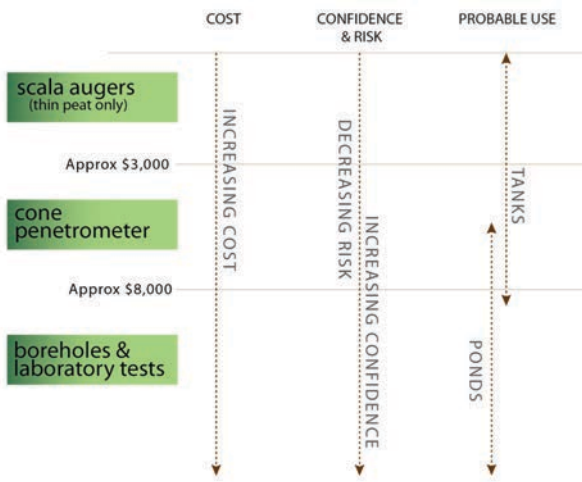

A discussion of “cost versus benefits” between the designer and farmer is essential during the investigation and design phases. This is to compare the cost of specific design and construction to mitigate settlement, against the cost of maintenance work that will be required over the life of the pond if this is not undertaken.

There is a wide range of possible variations in long-term maintenance costs. For example, annual topping up of pond embankments with associated adjustment of liners and pipework, once every five or even ten years. Maintenance costs can then be estimated and allowed for in the long-term farm business plan.

5.2 DESIGN PROCESS STEPS

Following the field investigation and laboratory testing of soil samples, tank and pond designers need to finalise their designs using the following steps:

Step 1:

From the information obtained from the ground investigation, designers need to calculate the bearing capacity of the peat, and compare that to the loading imposed by the proposed pond bank or tank.

If the peat cannot support the tank or pond without a shear failure occurring, the designer can assess possible remediation measures, including:

- Locating the pond or tank elsewhere
- Excavating out the peat
- Reducing the size of the pond or tank
- Including ground improvement measures such as “geogrid” or other proprietary products.

Step 2:

If the peat has sufficient bearing capacity, or after the design has been modified to meet the site conditions, the designer needs to assess the rate and degree of settlement likely to occur and compare this to the acceptable levels of settlement the proposed pond or tank can tolerate. The options then available are:

- If the primary settlement phase is sufficiently rapid and the secondary phase settlement not excessive, it may be possible to install the pond or tank after the primary settlement is complete.
- If the time taken for primary settlement to be complete and/or the secondary settlement is excessive, look to take remedial actions such as:
 - Locating the pond elsewhere
 - Removing peat if possible
 - Preloading
- Changing construction material. For example, considering light-weight fill or alternative liner type.

Step 3:

Assess effects of settlement on ancillary works such pipes, pump locations and drainage:

- Settlement can cause disruption of pipes and a reduction in, or even reversal of, drainage pipe gradients. This could have serious effects on gravity feeds and drain effectiveness
- Pipe penetrations through liners may become areas of stress and deformation. They need to be minimised and preferably avoided
- Low points, including sumps, in ponds and tanks to which FDE falls can move and pump or intake/outfall locations may need relocation. Floating pumps may be a suitable alternative to avoid relocation. Alternatively, fixed pump locations with movable intake pipes may be adopted
- Gas mitigation and venting measures need to be installed beneath any flexible geomembrane liner. These need to be vented at high points around the edge of the pond and if crowning of the pond base is anticipated, additional central venting points should be considered
- The risk of gas collection beneath large diameter tanks should be assessed by the designer and mitigation measures included if necessary. This can comprise a central vent or permeable granular mat beneath the tank
- Surface water drainage around pond sides and tanks needs to be assessed. Settlement of the tank or pond may lead to the collection and ponding of surface water around it. Surface water channels and subsoil drains to cut off surface and subsoil water will generally be needed.

6. SUMMARY

The following flow charts summarise the investigation, design and construction process for tanks and ponds on peat and supplement the process described in Part 1.

Figure 6.1: Flow Chart for Tanks on Peat

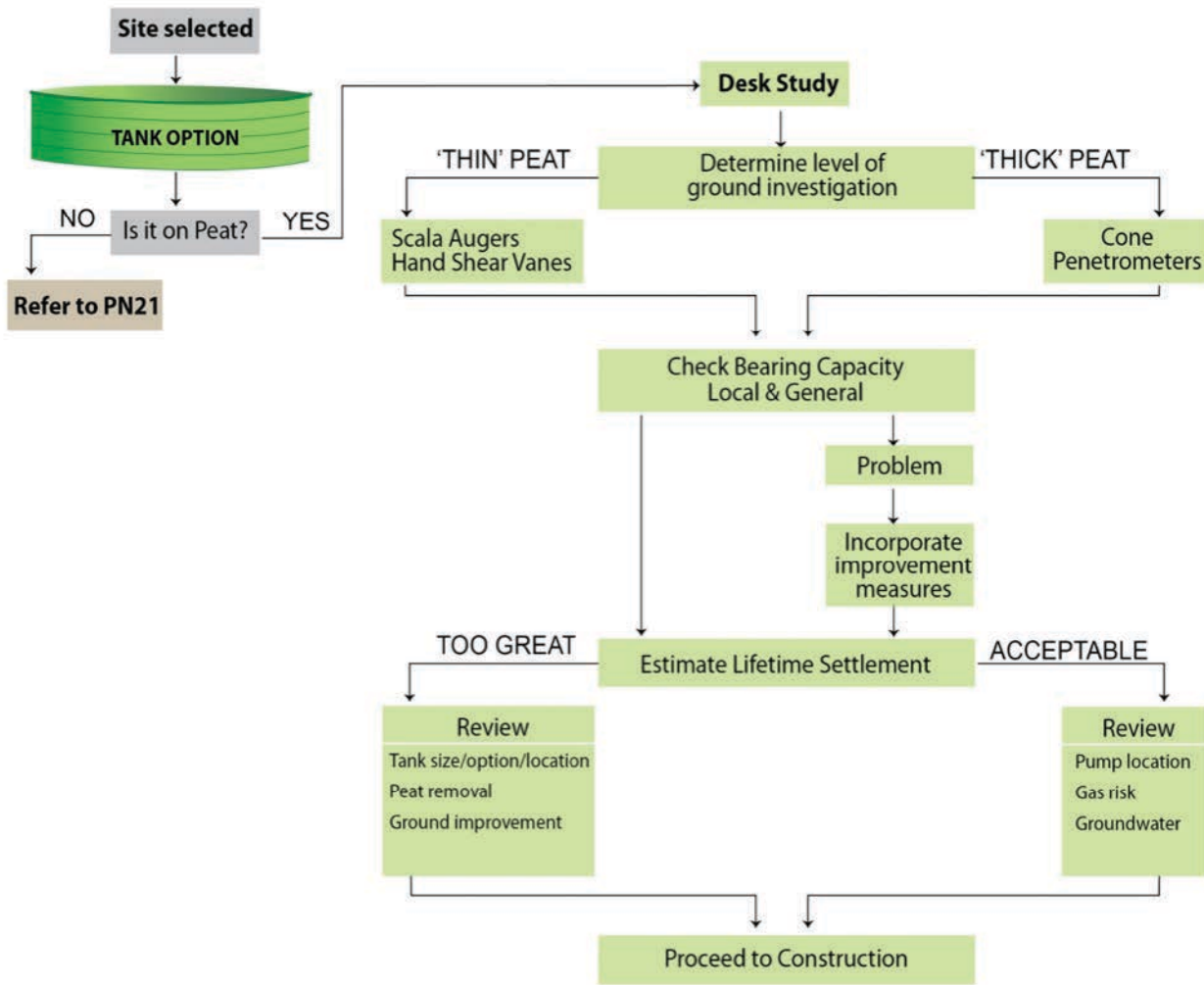
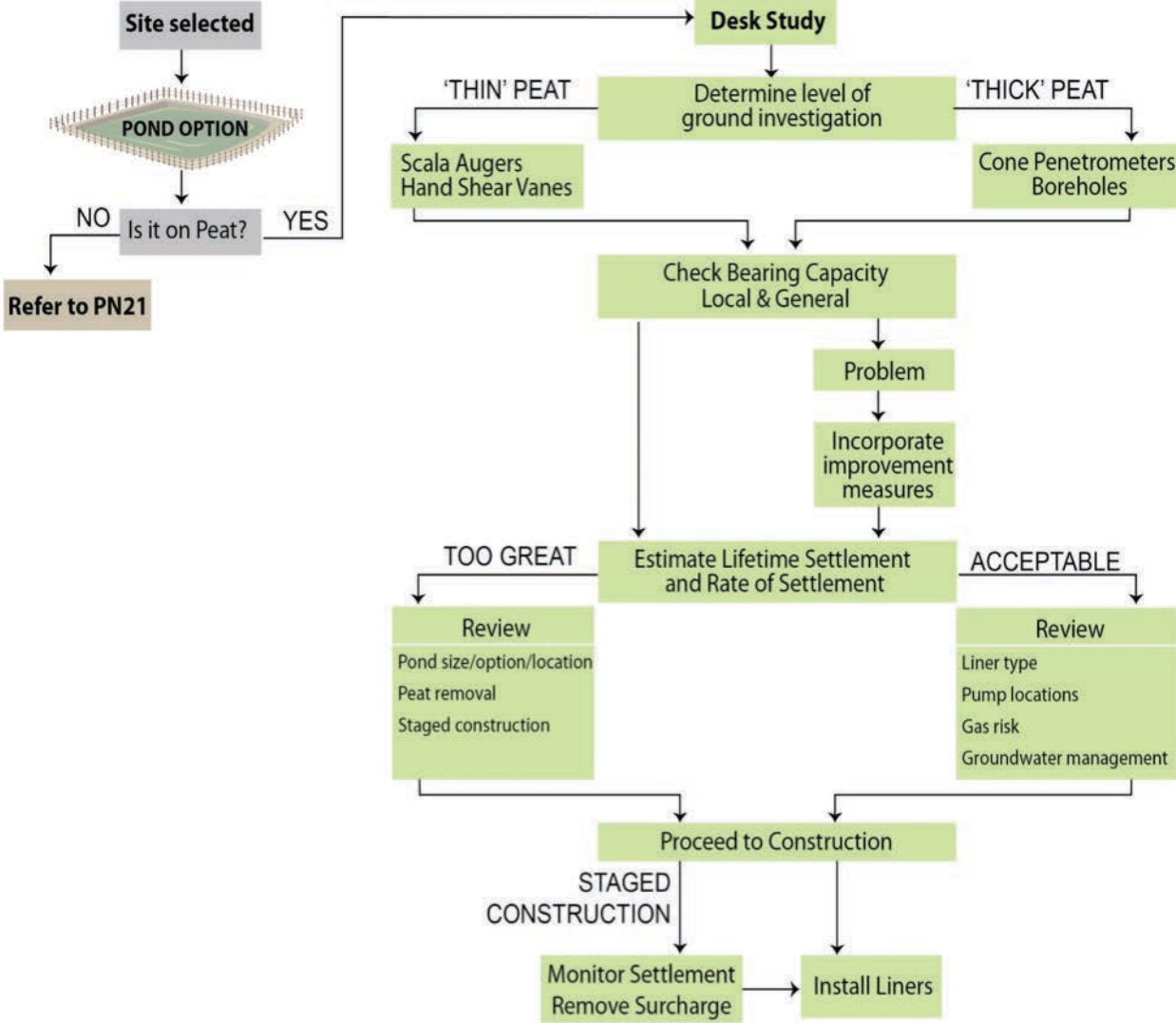

Figure 6.2: Flow Chart for Ponds on Peat



7. ACKNOWLEDGEMENTS

Figure 1: Figure 1, N B Hobbs, Mire Morphology and the Properties and Behaviour of Some British and Foreign Peats, *Quarterly Journal of Engineering Geology*, Vol 19, 1986.

Figure 3: Figure 3.1, N E Simons & B K Menzies, *A Short Course in Foundation Engineering*, Butterworths, 1977

Figure 6: Figure 1.2: Groundwater Control Design and Practice, CIRIA C515, 2000

Acknowledgement is given for figures from the above sources that have been modified for this document.

**PONDS AND TANKS
ON PEAT CASE STUDY
- HAURAKI MARINE CLAYS**

1. INTRODUCTION

The engineering principles for Farm Dairy Effluent (FDE) pond design and construction presented in *Practice Note 21 Farm Dairy Effluent Pond Design and Construction* should apply to all such ponds constructed in New Zealand.

However, the Hauraki Plains (the Plains) area has a unique geology for which a modified design and construction approach to FDE ponds can be appropriate. In some parts of the Plains, the firmer 'brown' clay which overlays the predominant Hauraki softer 'blue-grey' marine clays are of sufficient thickness and proximity to the surface that it can be practical to excavate a pond directly into this 'brown' clay and rely on its naturally low permeability to achieve a very low but acceptable leakage rate.

To assist the reader, a decision tree has been developed. This flow chart (Figure 4.CS.1) illustrates the decision steps necessary when the Hauraki 'Marine' clay geology profile is present.

Because of the variable subsurface geology and the engineering challenges that this creates, the early involvement of an experienced engineer is essential to ensure professional sign-off can be provided (if required) to the Regional Council.

Objectives of *Practice Note 21, Part 4 Case Study*

- To characterise the geology and identify geographic locations where suitable Hauraki 'Marine' clay materials for FDE ponds can be expected
- To identify relevant engineering properties and describe how these influence FDE pond construction
- To develop a specific methodology for the investigation, design and construction of ponds from these clays.



Pond Under Construction

Figure 4.CS.1: Decision Tree – for FDE Pond Design and Construction with Hauraki ‘Marine’ Clays

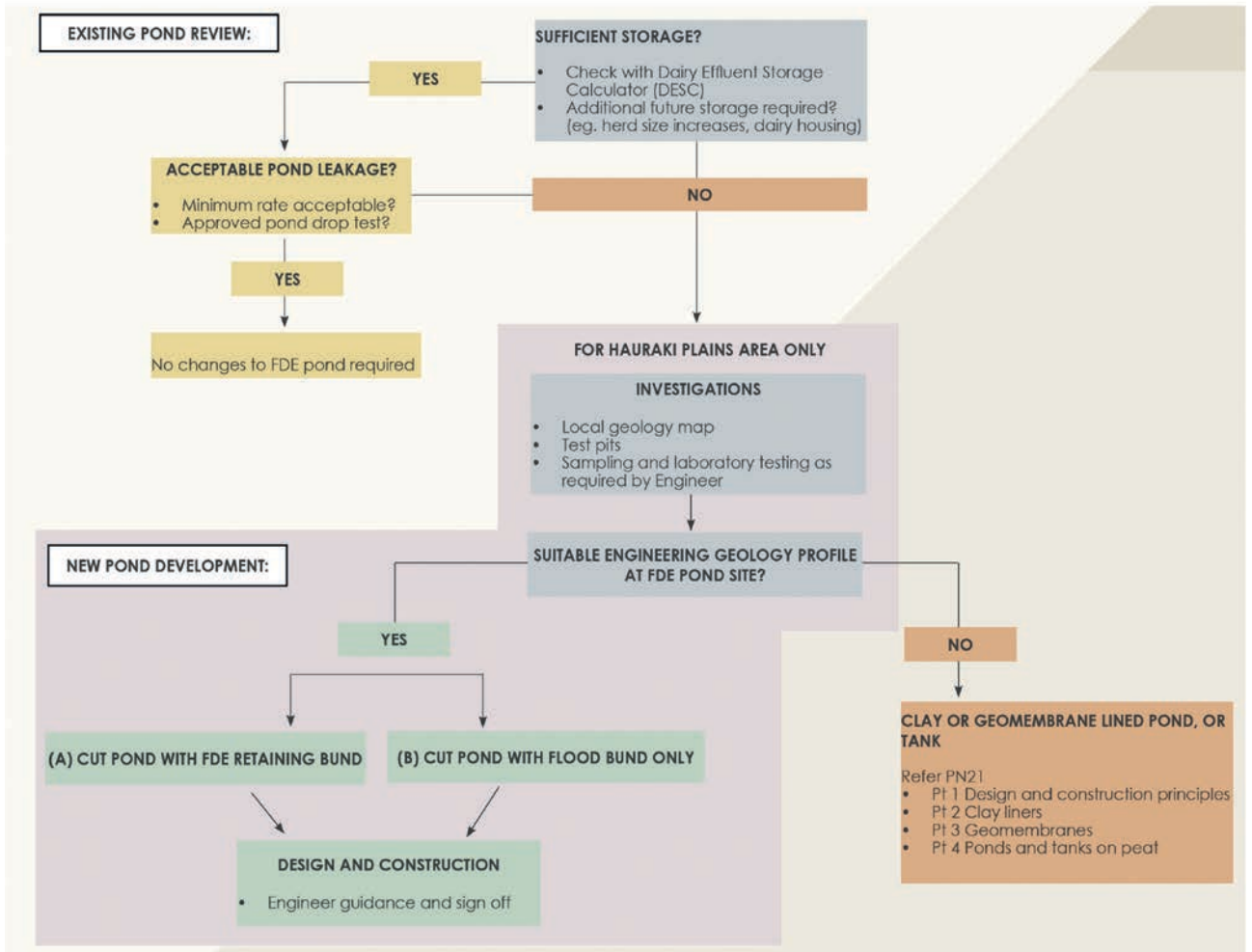

2. GEOLOGY

2.1 HAURAKI ‘MARINE’ CLAYS

Clay soils are made up of miniscule plate like mineral grains that have been formed from the weathering, alteration and physical breakdown of rock fragments. These are generally deposited in large rivers, deep seas and estuaries.

Estuarine formed ‘blue-grey’ clay soils found across the Hauraki Plains are colloquially known as Hauraki ‘Marine’ Clays. They can occur close to the ground surface level but can also be present at greater depths where they can be overlain by peat and more geologically recent colluvial deposits. These clays are typically interbedded with thin layers of peat, sand and shells, are generally ‘blue-grey’ in colour but where they are near the surface they tend to have a firmer weathered ‘brown’ layer of variable thickness as illustrated in the pit below.

Figure 4.CS.2: Typical Hauraki “Marine” Clay Soil Profile

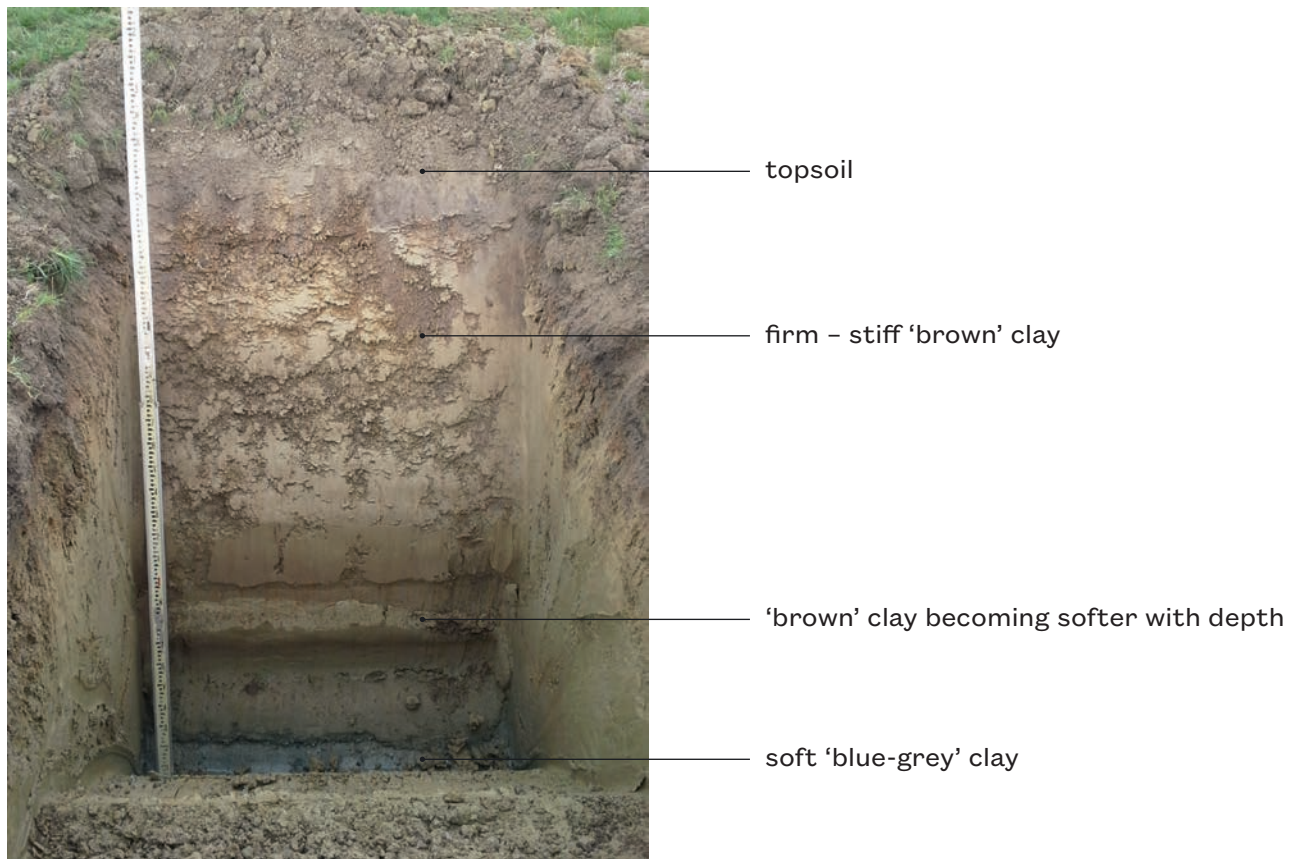

On the east and west margins of the Plains the clay may be overlain by sand and silt washed down from the adjacent hill sides. To the south there is a mix of the predominantly sandy soils and the clay which has been buried under sandy soils eroded by former river channels is now infilled with layers of sand, silt, clay and peat.

Peat and organic soils are found all over the Plains at the ground surface and in buried layers within the marine clays and sand/silt deposits. Occurrence of the peat is highly variable presenting as small isolated pockets in surface depressions as thin continuous layers but also as deep thick deposits in the central Plains area.

2.2 SUITABLE LOCATIONS

A Hauraki ‘Marine’ Clay location plan as presented in Figure 4.CS.3 has been developed using published geological maps, historic borehole and other information to assist in identifying where:

- The top of the clay layer is likely to be more than 2.5 m below the ground surface; and
- Areas where the clay layer is likely to be less than 5 m thick.

The significance of these two criteria to FDE pond designers are:

- If the top of suitable clays is more than 2.5 m below ground level, the influence of it on final pond design will be reduced to the point where ‘conventional’ pond design issues (as described in *Practice Note 21*) dominate; and
- If the bottom level of competent clays is less than 5 m below ground surface level, then there is a risk of there being too thin a layer of suitable clay beneath the pond base to be confident of achieving a low permeability naturally sealed pond.

For all ponds a specific onsite assessment needs to be made of the remaining *in situ* ‘brown’ clay below the intended pond base level.

2.3 PROFILE VARIABILITY

Organic clays or peats occurring within the Hauraki ‘Marine’ clay profile can be very soft and compressible. They can also generate preferred flow paths for groundwater and methane generated by the decomposition of the peat. These layers can increase the settlement and instability risk of pond perimeter bunds.

Sand and shell layers within the excavated sides of a pond can lead to inflows of groundwater and conversely outflows of effluent. Where significant inflow occurs, it can also cause erosion of the layer, undercutting the sides and promoting instability.

While Hauraki ‘Marine’ clay soils are usually firmer and have more strength near the surface, they soften with depth to the approximate water table, then slowly increase in strength with depth below this. The firmest soils are the near surface oxidised ‘brown’ clays which overlie the deeper below water table ‘blue-grey’ clays. The depth at which this transition occurs is critical to pond design decisions and will vary from farm to farm.

Where sand or peat layers are absent from the ‘brown’ clays, and more than 1 m below the base and sides of a pond, these sites can be suitable for excavating directly into to construct a complying FDE storage pond.

This ‘brown’ clay, and other near surface firm to stiff clays, are also usually suitable for reuse in construction of liners and bunds.

Figure 4.CS.3: Hauraki 'Marine' Clay Location Plan

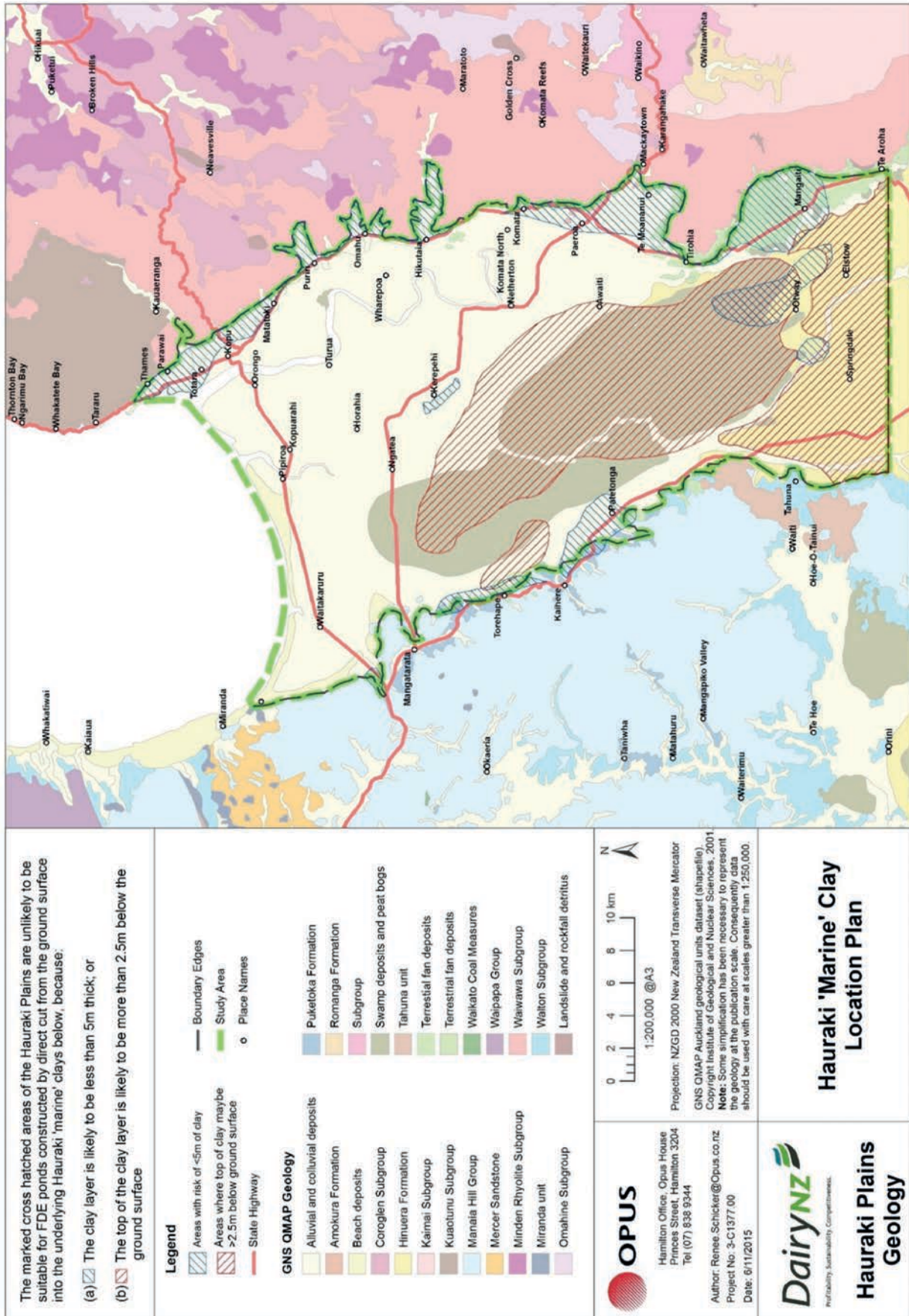

3. ENGINEERING PROPERTIES

3.1 SHEAR STRENGTH

The term shear strength is used to describe the magnitude of the loading that a soil can sustain and is an indicator of a soils strength.

Importantly, soils of shear strengths below about 70 kilopascals (kPa) are sticky, become increasingly difficult to work with and compact without a bow-wave forming in front of the roller. Below 50 kPa these soils become unworkable.

Conversely, stiffer soils, typically above 120 kPa may not breakdown and remould as needed to achieve minimum compaction and voids targets.

The actual strength at which the clay can become too difficult to work depends in part on the size and weight of roller used, as well as water content. While a lighter roller may work more effectively than a heavier roller on a softer clay, additional roller passes and reduced lift depths may be necessary to achieve the required compacted density.

3.2 CRACKING

Marine clays have high plasticity contributing to a high shrinkage and swell capability on drying and wetting. Summer cracking in these clays of up to 30 mm wide and up to 600 mm deep have been observed. In the winter these cracks close-up as increased moisture availability causes the clay to swell.

If a clay liner is placed over a highly permeable stratum such as coarse sand, it will need to be over 1 m thick to ensure that there is an intact 450 mm depth of clay liner always, or alternatively be protected from drying out by topsoil cover or continually maintaining some effluent/water in the pond.

3.3 PERMEABILITY

The recommended acceptance level for a 450 mm thick clay liner is a permeability of not greater than 1×10^{-9} m/s. For clays with test values marginally above this, and if there is a clay layer thickness significantly greater than 1 m below the finished base and sides of the pond, then no further sealing should be required.

However, each case should be assessed by an engineer, and the possible seepage rate for anticipated effluent heads compared against the equivalent for 450 mm of clay liner. Allowance for possible shrinkage of the clay as described will also be necessary.

3.4 SETTLEMENT

Previous earthworks in the Plains area indicates that a 2-metre-high-bank constructed of Hauraki 'Marine' clays can consolidate and vertically settle under its own mass by 200 to 400 mm with 60 to 80 per cent of this occurring in the first year after construction.

In areas with compressible peat layers beneath this, settlement risk is significantly increased. Common issues and solutions associated with working in peat areas are addressed in *Practice Note 21*.

4. INVESTIGATIONS

4.1 SITE INVESTIGATIONS

The purpose of site investigations is to provide accurate information into the design.

The first step is to locate the proposed pond site on the Figure 4.CS.3 geology map to predict the likely materials profile and expected depth that a pond might be able to be excavated to.

Investigations should then be undertaken by an experienced engineer or geologist and include a minimum of four test pits excavated to a depth of at least 4 m. So that an assessment of shear strength against depth can be developed, field testing should include shear vane tests.

Table 4.CS.1 Key Observations

Key Observation	Comment
Presence, thickness, strength of the stiffer 'brown' clay layer	The viability and performance of a pond cut directly into the 'brown' marine clay is dependent on the clays consistency, thickness and proximity to the surface.
Depth to the top of the softer 'blue' clay and its strength	If the underlying strata is too soft it may not be possible for overlying compacted material to achieve the necessary percentage of compaction (and permeability). Adopting an alternative design, or installing a synthetic pond liner may be more practical.
Presence or sand, shell or peat layers in the upper 4 m of the ground profile and if its occurrence is localised or extensive?	Where unsuitable sand, shells and peat layers are present, an assessment should be made as to the practical feasibility of removing any such layers. Options are: (a) Unsuitable localised layers can be excavated out at least 1 m back along from the face of the pond slope. To provide a sealed lining to the pond this area can be "chased-out" and replaced with excavated firm 'brown' clay and given sufficient compaction; or (b) Where unsuitable layers are more <u>extensive</u> or numerous, then other pond construction (or tank) options will need to be considered.
Groundwater level (GL) and level risen to if water flow is from a sand or permeable layer	The dry appearance of test pits in clay may not mean the groundwater level is below the pit level but be reflective of the low permeability of the clay preventing side seepage into the pit.

A final investigation step is to confirm by using available earthworks equipment that the excavated clay can be compacted to a point where it will:

- Meet the permeability criteria
- Be strong enough to form stable slopes
- Not be so soft it will form a wave in front of the roller used to compact it
- Not be so stiff it will not compact properly.

This investigation sets the standard of compaction that can be achieved on site. A target of 95% maximum dry density with a voids content of less than 10% is usually possible.

4.2 LABORATORY TESTING

If it is intended to use excavated clay soils to construct bunds which will be effluent retaining, then sufficient test pit samples will need to be taken for:

- A laboratory compaction test (dry density/water content relationship)
- A permeability test at the target maximum dry density.

Hand shear vane tests on compaction test samples at the laboratory will provide a useful means of result comparison later during construction.

Table 4.CS.2: Limitations of Working with Hauraki ‘Marine’ Clay

Limitations of Working with Hauraki ‘Marine’ Clay

- As Hauraki clays are typically soft and wet there are associated constructability risks
- An adequately firm subgrade surface will be required to roller compact fill on to achieve target compaction
- Risk can be reduced by setting the excavation maximum depth limit for the base of the pond just above the brown-blue clay boundary. The depth to the ‘blue-grey’ clay and the strength of the ‘brown’ clay must be continually monitored during construction
- Digging deeper into the clay increases the chances of uncovering unexpected seepages. The ‘blue’ clay is mostly saturated and below the watertable and can lead to buoyancy lift of the pond base when effluent is removed from operational ponds.

5. DESIGN

5.1 BUNDING

All FDE ponds require a bund of sufficient height constructed around the top of the pond incorporated into its design to cut off the inflow of surface water, including flood water.

All bund construction will require removal of topsoil and undercutting down to the top of the competent 'brown' clay. Note that the height of the bund effectively starts at this level, even though it may be below the surrounding ground level.

There are two bund construction options for below ground cut ponds available depending on whether the bund itself is intended to retain FDE as illustrated in Figure 4.CS.3.

Table 4.CS.3 Bunding Options

Bund Retaining Options	
Option (A) FDE Retaining Bund	Construct with suitable excavated firm 'brown' clay, tested and placed in accordance with <i>Practice Note 21</i> .
Option (B) Flood Bund Only	Construct with excavated clay and some roller compaction.

5.2 POND SIZING

All ponds must be designed to provide sufficient FDE storage as determined by Massey University's Dairy Effluent Storage Calculator (DESC). Where the flood bund option is adopted, the volume contained above the level of the bund base must not be used for FDE storage, or as a working "freeboard".

Often the limitation with shallow soft soils is that to obtain the required storage volume only a relatively shallow pond can be excavated, but this requires a larger pond plan area with an increased rainfall catchment.

5.3 ADDITIONAL DESIGN RECOMMENDATIONS

All designs should follow the good practice guidelines as detailed in *Practice Note 21* with the following additional recommendations:

Position the base of the pond a **minimum** of, either 500 mm above the top of any soft clay, or 1 m above a permeable layer – whichever is the deeper.

If groundwater is present in a sand or permeable layer below the intended pond base level, ensure there is sufficient clay left above this layer to prevent base heave from hydrostatic uplift. The minimum clay thickness required to achieve this is best determined by an engineer.

Figure 4.CS.4: Bund Construction Options

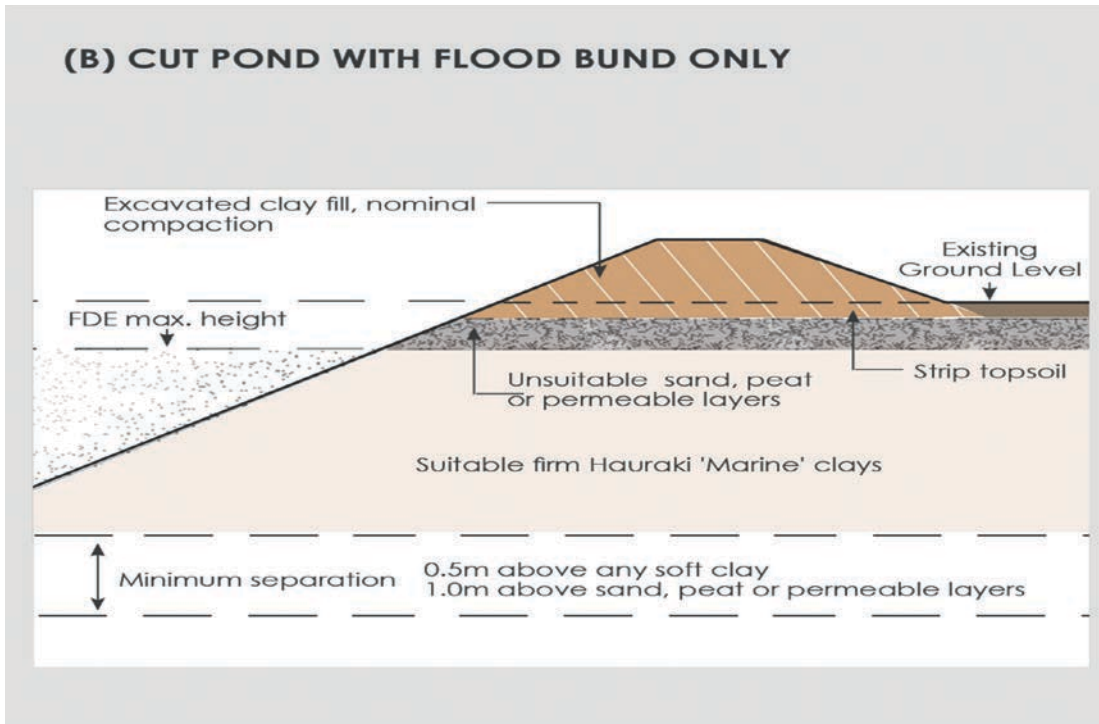
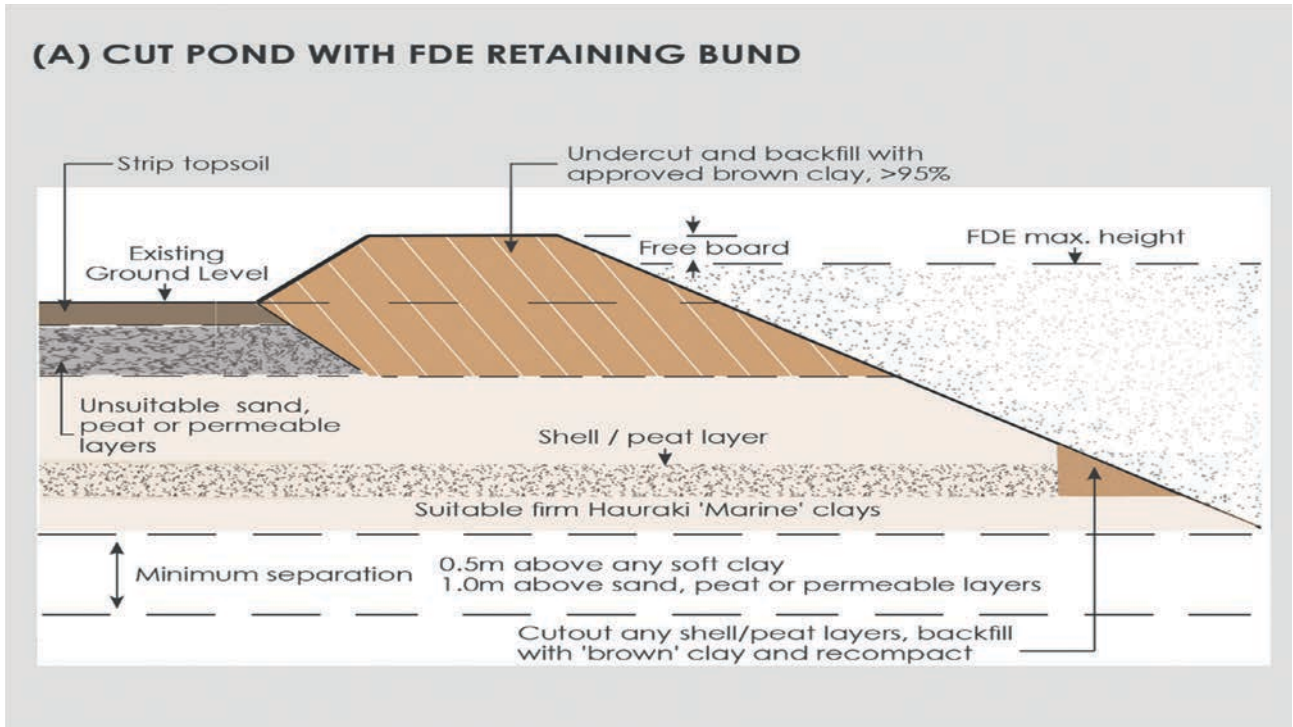

6. CONSTRUCTION

6.1 BUND CONSTRUCTION TESTING

Option A – Cut Pond with FDE Retaining Bund

For *Option A*, the fill placement, compaction and testing practices for constructing the bund as described in *Practice Note 21* should be followed, particularly:

- The relationship between shear vane strength, the percentage of air voids achieved and the target permeability must be established from prior laboratory testing
- These results can then be used as a basis to monitor the onsite compaction to confirm that density and air voids percentage is being achieved by using a hand shear vane together with less frequent Nuclear Density Meter (NDM) measurements. A shear vane is a very useful tool for monitoring changes in soil shear strength with changes in the compactive effort being applied
- By carrying out an engineer supervised trial compaction in advance of the main construction works for the bund, the optimum layer thickness and number of passes required by the chosen roller to achieve the target compaction can be established
- Using this approach, quality assurance site testing during construction using the NDM may be reduced to the minimum as shown in *Practice Note 21*, Part 2 Table 6.1.

Option B – Cut Pond with Flood Bund Only

For *Option B*, less compaction for bund construction than *Option A* can be acceptable as the formed bund only needs to retain surface and flood water. No on site testing is necessary. However, if localised sand, shell and peat layers are encountered, these will need to be “chased-out” and suitably backfilled and compacted to provide a seal.

As it will become less apparent over time where the maximum FDE level that the pond has been designed and constructed to is, it must be clearly marked with large coloured timber pegs or similar markers so that it is not over filled.



Trial Compaction Area Preparation

6.2 HEALTH AND SAFETY

When a pond is constructed, regardless of location, the pond becomes a construction site and is controlled by the Health and Safety at Work Act 2015. See Part 1 section 3.2.

Table 4.CS.4: Some Good Construction Practices

- Construction should be planned to be completed over the drier months. A wet spell in autumn may leave a pond partially constructed for months over winter. Early morning dew in autumn can lead to surface skidding and having to continually strip the wet surface, or allow drying out before placing more material.
- Some standard construction plant will get bogged in the soft clay and long reach excavators may be required. Compaction plant with a sheepsfoot roller on both the front and rear axles enables continual traction.
- Hauraki 'Marine' Clays tend to form a 'bow wave' in front of rollers being pushed along rather than being compacted. Lighter rollers, thinner lifts and more roller passes are usually required.
- After stripping topsoil to a stockpile, an initial compaction trial should be carried out under the direction of the engineer with these test results setting the compaction methodology for the earthworks
- Sides and the base of the pond must be continually monitored for unacceptable layers of sand, shells or peat
- Frequent shear vanes tests in combination with NDM tests must be used to control compacted bund soil density and air voids
- Active involvement by an experienced professional engineer is essential to ensure sign-off can be provided to the Regional Council.

REFERENCES

OVERVIEW

A selection of documents has been reviewed in preparing this Practice Note covering consenting, investigations, design, construction, and operation of FDE ponds.

This section provides a summary and links to relevant documents available.

PART 1: DESIGN AND CONSTRUCTION PRINCIPLES

NEW ZEALAND LEGISLATION

A GLOSSARY OF TERMS USED IN NEW ZEALAND LEGISLATION

www.legislation.govt.nz/glossary.aspx

BUILDING ACT 2004 NO 72

www.legislation.govt.nz/act/public/2004/0072/latest/DLM306036.html

BUILDING REGULATIONS (THE BUILDING CODE)

www.legislation.govt.nz/regulation/public/1992/0150/latest/whole.html#DLM162576

HEALTH AND SAFETY AT WORK ACT 2015 NO 70

www.legislation.govt.nz/act/public/2015/0070/latest/DLM5976660.html

RESOURCE MANAGEMENT ACT 1991 NO 69

www.legislation.govt.nz/act/public/1991/0069/latest/DLM230265.html

AUCKLAND REGIONAL COUNCIL

DAMS

www.aucklandcouncil.govt.nz/en/ratesbuildingproperty/consents/buildingstructures/pages/dams.aspx

DAIRY AUSTRALIA

EFFLUENT AND MANURE DATABASE FOR THE AUSTRALIAN DAIRY INDUSTRY

This is a detailed and comprehensive code of all aspects of FDE management for Australian conditions. Aspects of sections 2.4 (pond site investigations, p56–60) and 2.35 (pond design and construction, p61–66) are relevant in New Zealand.

www.dairyingfortomorrow.com.au/tools-and-guidelines/effluent-and-manure-management-database-for-the-australian-dairy-industry

DAIRYNZ

DAIRYNZ EFFLUENT RESOURCES

www.dairynz.co.nz/publications/environment/catalogue-of-effluent-resources

EFFLUENT SYSTEMS

www.dairynz.co.nz/environment/effluent

EFFLUENT STORAGE

www.dairynz.co.nz/environment/effluent/effluent-storage

DESIGNING OR UPGRADING EFFLUENT SYSTEMS

www.dairynz.co.nz/environment/effluent/designing-or-upgrading-effluent-systems

PLANNING THE RIGHT SYSTEM FOR YOUR FARM

www.dairynz.co.nz/publications/environment/farm-dairy-effluent-fde-systems-planning-the-right-system-for-your-farm

A FARMER'S GUIDE TO BUILDING A NEW EFFLUENT STORAGE POND

www.dairynz.co.nz/publications/environment/a-farmers-guide-to-building-a-new-effluent-storage-pond

ENVIRONMENT BAY OF PLENTY

The following document reviews the use of seepage collars in small dams and proposes adopting filter collars and discontinuing with seepage collars.

www.boprc.govt.nz/media/33310/report-060900-reviewuseseepagecollarsinsmalldams.pdf

INSTITUTION OF PROFESSIONAL ENGINEERS NEW ZEALAND (IPENZ)

IPENZ CODE OF ETHICAL CONDUCT

This code describes the ethical obligations of IPENZ members in their engineering activities.

CPENG CODE OF ETHICAL CONDUCT

This code describes the ethical obligations of Chartered Professional Engineers in their engineering activities.

IPENZ/ACENZ SHORT FORM AGREEMENT FOR CONSULTANT ENGAGEMENT

This is a recommended standard contract form between a consultant and a client, including model conditions of engagement. There is space to include scope and nature of services, programme for the services, fees and timing of payments, information or services to be provided by the client, and variations to the conditions of engagement.

www.ipenz.nz

NZSOLD - THE NEW ZEALAND DAM SAFETY GUIDELINES

www.ipenz.nz/home/news-and-publications/news-article/the-new-zealand-dam-safety-guidelines

MASSEY UNIVERSITY

FERTILIZER AND LIME RESEARCH CENTRE

Dairy Effluent Storage Calculator (Download and installation instructions)

www.massey.ac.nz/~flrc/required/FDE%20Calculator/Obtain_DESC.html

MINISTRY OF BUSINESS, INNOVATION AND EMPLOYMENT

DAMS

Provides information to dam owners, contractors and councils and their obligations to ensure dams are safe.

www.building.govt.nz/building-code-compliance/specific-buildings/dams

INDUSTRIAL LIQUID WASTE

This is the compliance document for clause G14 of the Building Code relating to industrial liquid waste. It quotes the relevant clauses from the Building Code contained in the first schedule of the Building Regulations 2005. The document describes the requirements to be satisfied by specific design for systems used for the collection, storage, treatment, and disposal of industrial liquid waste.

www.building.govt.nz/building-code-compliance/g-services-and-facilities/g14-industrial-liquid-waste

SAFETY FROM FALLING

The compliance document for the New Zealand Building Code for establishing compliance where Safety from Falling using barriers is contained in Clause F4 Safety from Falling – Third Edition (September 2007)

www.building.govt.nz/search/?keyword=safety+from+falling&search=

MINISTRY FOR THE ENVIRONMENT

ABOUT CONTAMINATED LAND IN NEW ZEALAND

www.mfe.govt.nz/land/about-contaminated-land-new-zealand

HAZARDOUS ACTIVITIES AND INDUSTRIES LIST (HAIL)

www.mfe.govt.nz/land/hazardous-activities-and-industries-list-hail

NELSON KD

DESIGN AND CONSTRUCTION OF SMALL EARTH DAMS

Published by Inkata Press, Melbourne, ISBN 0 909605 34 3

NEW ZEALAND GEOTECHNICAL SOCIETY

DESCRIPTION OF SOILS AND ROCKS

Guideline for the field classification and description of soil and rock for engineering purposes.

www.nzgs.org/library/field-description-of-soil-and-rock

STANDARDS NEW ZEALAND

NZS 3910:2003 (CONDITIONS OF CONTRACT FOR BUILDING AND CIVIL ENGINEERING CONSTRUCTION)

This is the most widely accepted form of contract for the design and construction of earthworks in New Zealand.

shop.standards.govt.nz/search/ed?q=3910

WORKSAFE NEW ZEALAND

WORKING AT HEIGHT IN NEW ZEALAND

construction.worksafe.govt.nz/guides/working-at-height-in-new-zealand

HEALTH AND SAFETY AT WORK

www.worksafe.govt.nz/worksafe/information-guidance/all-guidance-items/hswa-quick-reference-guide/HSWA-quick-reference-guide-december2016.pdf

CONSTRUCTION GUIDES

construction.worksafe.govt.nz/guides

SAFER FARMS

www.saferfarms.org.nz/guides

PART 2: CLAY LINERS FOR PONDS

LANDFILL GUIDELINES

Centre of Advanced Engineering. (2000).

Christchurch, New Zealand: University of Canterbury Centre for Advanced Engineering.

**“FULL-SCALE HYDRAULIC PERFORMANCE OF SOIL-BENTONITE AND COMPACTED LAY LINERS”
HARDY LECTURE, CHAPUIS R, 2002, THE 2000 R.M, CANADIAN GEOTECHNICAL JOURNAL, VOL 39,
PP 417 TO 439.**

Waste Containment Facilities, Guidance for Construction, Quality Assurance and Quality Control of Liner and Cover Systems.

Daniel D.E. and Koerner R.M. (1995). New York, United States of America: American Society of Civil Engineers.

SOIL MECHANICS IN ENGINEERING PRACTICE, 3RD EDITION.

Terzaghi K, Peck R.B. and Mesri G. (1996). New York, United States of America: John Wiley & Sons.

GEOTECHNICAL ENGINEERING IN RESIDUAL SOILS.

Wesley. (2010). Hoboken New Jersey, United States of America: John Wiley & Sons.

PART 3: GEOMEMBRANE (SYNTHETIC LINER) SELECTION

UNITED STATES DEPARTMENT OF AGRICULTURE (USDA)

POND SEALING OR LINING COMPACTED CLAY TREATMENT, CODE 521D, SEPTEMBER 2010, NATURAL RESOURCES CONSERVATION SERVICE, CONSERVATION PRACTICE STANDARD

www.nrcs.usda.gov/Internet/FSE_DOCUMENTS/stelprdb1046899.pdf

GEOSYNTHETIC INSTITUTE

GRI SPECIFICATIONS

www.geosynthetic-institute.org/specifications.htm

A GUIDE TO POLYMERIC GEOMEMBRANES, A PRACTICAL APPROACH, WILEY SERIES
IN POLYMER SCIENCE, SCHEIRS, JOHN

www.wiley-vch.de/en?option=com_eshop&view=product&isbn=9780470519202&title=A%20Guide%20to%20Polymeric%20Geomembranes

APPENDIX A – REGULATORY CHECKLIST

DISTRICT COUNCIL – RMA

Preliminary

- Which district and zone?
- What district plans? There may be more than one that is applicable.
- Is the area of excavation listed on the HAIL?

Specifics

- Is construction and ongoing operation of an FDE pond a Permitted Activity?
- Does the plan provide performance standards for effluent ponds as Permitted Activities?
- Are separations specified? Check distances to roads, boundaries, houses, residential zones, marae.
- Are there limitations on the earthworks' depth, volume, or timing?
- Can Permitted Activity criteria/performance standards be met, or is there a need to go back to the District Council for consenting? If so, ensure any conditions are met.
- Identify certification requirements; these will frequently involve stability of earthworks.
- Undertake certification as required.

REGIONAL COUNCIL – RMA

Preliminary

- Which region?
- What regional plans? There may be more than one that is applicable. Identify driver for pond requirement. Is it as a condition of Resource Consent? Is it to meet a standard for a Permitted Activity? Is it for some other reason? List standards, conditions, requirements.

Specifics

- Is the volume requirement specified in a plan or consent?
- Are separations specified? Check distances to water bodies, bores, wetlands.
- Is the permeability limit specified in the plan or consent?
- Can the pond be installed without diversion of any watercourse?
- Can pond be installed without breaching a Regional Council earthworks consenting requirement?
- Can the above criteria be met, or is there a need to go back to the RC for further consenting? If so, ensure any conditions are met.
- Identify certification requirements; this will frequently include permeability.
- Undertake certification as required. Note: contractors fitting synthetic pond liners can be required to certify the permeability of the installed liner.

Table A.1 provides a broad overview of the resource consent requirements for effluent discharge to water and land within each region as well as any relevant design guidelines for FDE pond construction. Please note this table is indicative rather than definitive and subject to change. In all instances, the rules of the relevant regional/district council should be consulted directly. Rules may subject to change or variation at any time and or the interpretation of such rules can often differ. Given the sensitivity of potential effects from effluent on soil and water, certainty around resource consent requirements is recommended.

Table A.1: Regional Council Effluent Discharge Requirements and Guidelines for the Design of Effluent Ponds

Region	Effluent discharge to water	Effluent discharge to land	Effluent pond size	Seepage/permeability
Northland	Yes*	<p>Permitted – subject to meeting all conditions of the relevant rules in the Regional Water and Soil Plan for Northland.</p> <p>Permitted- subject to meeting all conditions of the relevant rules in the Draft Northland Regional Plan (not operative, please check status of the plan when assessing).</p>	<p>The Northland Regional Council’s farm dairy effluent team will provide recommended minimum storage volumes on a case-by-case basis, on request.</p> <p>Refer to the Draft Northland Regional Plan for pond sizing requirements.</p>	<p>No more than minor contamination of groundwater by seepage.</p> <p>Refer to the Draft Northland Regional Plan for design requirements.</p>
Auckland	Yes*	Permitted – subject to meeting all conditions of the relevant rules in the Auckland Unitary Plan.	Refer to specifications in the Auckland Unitary Plan for the guidance on storage volumes.	Refer to specifications in the Auckland Unitary Plan for guidance on sealing of storage systems.
Waikato	Yes*	<p>Permitted – subject to meeting all conditions of the relevant rules in the Waikato Regional Plan (outside the Taupo Catchment). Specific Rules apply to the Taupo Catchment.</p> <p>Permitted- subject to meeting all conditions of the relevant rules in the Proposed Waikato Regional Plan Change 1 – Waikato and Waipa River Catchments.</p>	Not specified but strongly recommend use of IPENZ design.	Sealing standard is 10^{-9} m/s.
Bay of Plenty	Yes*	<p>Controlled – subject to meeting all conditions of the relevant rules in the Bay of Plenty Regional Water and Land Plan.</p> <p>Refer to Plan Change 10 if the activity is within the Lake Rotorua Catchment.</p>	Refer to Managing Dairy Effluent Bay of Plenty and Recommend use of DESC**.	Refer to the Guide to Managing Dairy Effluent Bay of Plenty.

Region	Effluent discharge to water	Effluent discharge to land	Effluent pond size	Seepage/permeability
Taranaki	Yes*	Controlled – subject to meeting all conditions of the relevant rules in the Taranaki Regional Fresh Water Plan. Controlled – subject to meeting all conditions of the relevant rules in the Draft Freshwater and Land Management Plan (not operative, please check status of the plan when assessing).	Refer to the Taranaki Regional Freshwater Plan for guidelines. Refer to the Draft Freshwater and Land Management Plan for volume requirements.	Refer to the Taranaki Regional Council Dairy Effluent Pond Guidelines. Refer to the Draft Freshwater and Land Management Plan for sealing requirements.
Horizons	No	Controlled – subject to meeting all conditions of the relevant rules in the One Plan.	According to DESC**.	Must be sealed and permeability of the sealing layer must not exceed 1×10^{-9} m/s.
Hawke's Bay	No	Controlled – discretionary in sensitive catchments – subject to meeting all conditions of the relevant rules in the Regional Resource Management Plan and the Regional Coastal Environmental Plan.	Must use Massey University/ Horizons Regional Council Pond Storage Calculator (DESC**).	10^{-9} m/s.
Wellington	No	Controlled – subject to meeting all conditions of the relevant rules in the Regional Plan for Discharges to Land. Controlled – subject to meeting all conditions of the relevant rules in the Proposed Natural Resources Plan for the Greater Wellington Region.	Recommend use of DESC** as noted in Dairy Effluent Storage guide prepared by Wellington Regional Council. Refer to the Proposed Natural Resources Regional Plan for the Greater Wellington Region for pond sizing requirements.	Permeability of any liner should not be less than 1×10^{-9} m/s.
Tasman District	Yes*	Permitted- subject to meeting all conditions of the relevant rules in the Tasman Resource Management Plan.	Recommend use of DESC**.	The permeability of the sealing layer must not exceed 1×10^{-9} metres per second (m/s).

Region	Effluent discharge to water	Effluent discharge to land	Effluent pond size	Seepage/permeability
Marlborough District	No	Permitted – subject to meeting all conditions of the relevant rules in the <ul style="list-style-type: none"> • Marlborough Sounds Resource Management Plan • Wairau/Awatere Resource Management Plan • Proposed Marlborough Environment Plan. 	Refer to the Proposed Marlborough Environment Plan which specifies details for on-site storage systems and for new dairy farms established after 9 June 2016.	Refer to the Proposed Marlborough Environment Plan.
West Coast	Yes*	Permitted or controlled activity (if within the Lake Brunner Catchment) – subject to meeting all conditions of the relevant rules in the Land and Water Plan.	Size calculated on number of cows-see West Coast A guide to managing Farm dairy effluent.	Refer to West Coast “A guide to managing Farm dairy effluent”.
Canterbury	No	Restricted Discretionary – subject to meeting all conditions of the relevant rules in the Canterbury Land and Water Regional Plan.	Must demonstrate adequacy, recommend use of the DESC**.	Refer to the Canterbury Land and Water Regional Plan for details.
Otago	No	Permitted – subject to meeting all conditions of the relevant rules in the Otago Regional Council Water Plan.	Minimum size recommended is 50 litres/ cow/day – see Environmental Considerations for managing dairy effluent application to land in Otago.	Recommend storage system sealed to prevent seepage – see Environmental Considerations for managing dairy effluent application to land in Otago.
Southland	No	Permitted – subject to meeting all conditions of the relevant rules in the (Proposed) Southland Water and Land Plan.	Rule 32 – Effluent storage Rule 35 – Discharge of agricultural effluent to land Appendix P – Effluent Pond Drop Test methodology of the Proposed Southland Water and Land Plan.	

* Please note this table is indicative rather than definitive and subject to change with consent

** DESC Dairy Effluent Storage Calculator

BUILDING ACT

Does the pond involve a dam?

- If the fluid level in the pond will rise above the level of the surrounding land, then a dam is involved, and the RC is the administering authority.
- If the dam is greater than 4 m high **and** impounds more than 20,000 m³ of fluid (that is, it is a large dam), then a Building Consent will be required; an application should be prepared and lodged with the RC. The design and construction will need to comply with the approved plans and Building Consent conditions, verified by certification.
- If the dam is lower than 4 m **and** it impounds less than 20,000 m³ of fluid, then a Building Consent from the RC is not required, but the dam must be designed and constructed in compliance with Building Code requirements, and verified by certification.

What if the pond does not involve a dam?

- If the fluid level in the pond will not rise above the level of the surrounding land, then a dam is not involved and the District Council is the administering authority.
- Check with the building inspector whether the walls of the pond will be a retaining wall, and whether a Building Consent will be required. The three-metre height exemption for a retaining wall in a rural zone and designed by a CPEng should excuse most ponds from a Building Consent requirement.
- If consent is required, an application should be prepared and lodged with the District Council. The design and construction will need to comply with the Building Consent conditions, and verified by certification.
- If consent is not required, the walls of the pond should still be designed and constructed in compliance with the Building Code standards, and verified by certification.

HISTORIC PLACES ACT

- Has the district plan been checked as to whether the proposed works may affect known heritage or archaeological sites?
- Are there archaeological discovery protocols in place?

NATIONAL ENVIRONMENTAL STANDARD FOR ASSESSING AND MANAGING CONTAMINANTS IN SOIL TO PROTECT HUMAN HEALTH (NESCS)

- Has the site been checked on the HAIL?
- If the site is identified on HAIL does it require consent under the NESCS?

DISCLAIMER

DairyNZ Limited (“DairyNZ”, “we”, “our”) and the Institution of Professional Engineers New Zealand (IPENZ), collectively “we”, endeavour to ensure the information in this Practice Note is accurate and current. However, we do not accept liability for any error or omission, nor can we be held responsible for its accuracy, currency, or fitness for purpose as good practice is subject to change without notice.

The information in this Practice Note is intended to provide the best possible advice DairyNZ and IPENZ have access to. It is important to note the information is provided as general guidance only and is not intended as a substitute for specific advice. While every care is taken in its preparation, this document is not offered as formal advice and readers must exercise their own professional skill and judgement in its application. Practices, systems, and advice may vary depending on the individual circumstances. The information may also be subject to change at any time without notice. DairyNZ and IPENZ take no responsibility whatsoever for the currency and/or accuracy of this information, its completeness, or fitness for purpose.

The images used in this Practice Note are representative of aspects of Dairy Effluent Ponds. They may not reflect all aspects of good practice guidance contained in this Practice Note.

COPYRIGHT

Copyright in this publication (including text and graphics) is owned or licensed to DairyNZ.

Other than for the purposes of, and subject to the conditions prescribed under, the Copyright Act 1994 and similar legislation which applies in your location, and except as expressly authorised by these terms and conditions, you may not in any form or by any means adapt, reproduce, store, distribute, print, display, perform, publish, or create derivative works from any part of this publication or commercialise any information, products, or services obtained from any part of this publication without our written permission.



To facilitate the delivery of this Practice Note, DairyNZ as sponsor have engaged Opus International Consultants Ltd as the lead consultant.

EDITOR/LEAD AUTHOR

Rex Corlett FIPENZ, CPEng
Principal Engineer – Rural
Opus International Consultants
Christchurch, New Zealand
Rex.Corlett@opus.co.nz



© DairyNZ 2017

Version History

Version 3 – August 2017

The Institution of Professional Engineers New Zealand Inc
Pūtahi Kaiwetepanga Ngaio o Aotearoa

PO Box 12 241
Wellington 6144
New Zealand

P +64 4 473 9444
E ipenz@ipenz.org.nz
   EngineersNZ